

V2.3-2026-05-22

# Hybrid Inverter

**EH Series/EH Plus Series  
3.6-6kW User Manual**

**GOODWE**

# Copyright Statement

**Copyright© GoodWe Technologies Co., Ltd. 2026. All rights reserved.**

Without authorization from GoodWe Technologies Co., Ltd., no part of this manual may be reproduced, disseminated, or uploaded to public networks or other third-party platforms in any form.

## **Trademark Authorization**

**GOODWE** and other GOODWE trademarks used in this manual are the property of GoodWe Technologies Co., Ltd. All other trademarks or registered trademarks mentioned in this manual belong to their respective owners.

## **NOTICE**

Due to product version upgrades or other reasons, the content of this document is updated periodically. Unless otherwise agreed, the content of this document cannot replace the safety precautions on the product label. All descriptions in this document are for guidance only.

## Table of Contents

1 Preface	6
1.1 Applicable Model	6
1.2 Applicable Personnel	6
1.3 Symbol Definition	6
2 Safety Precautions	8
2.1 General Safety	8
2.2 PV String Safety	8
2.3 Inverter	9
2.4 Battery Safety	10
2.5 personnel requirements	11
2.6 EU Declaration of Conformity	12
2.6.1 Equipment with Wireless Communication Modules	12
2.6.2 Equipment without Wireless Communication Modules	13
3 Product Introduction	14
3.1 Product Overview	14
3.1.1 Function Overview	14
3.1.2 Model Description	14
3.1.3 Supported Grid Types	15
3.2 Application Scenarios	15
3.3 Working Modes	18
3.3.1 System Working Modes	18

3.3.2 Inverter Operating Modes.....	21
3.4 Features.....	23
3.5 Appearance Description.....	24
3.5.1 Appearance Description.....	24
3.5.2 Dimensions.....	24
3.5.3 Indicator Description.....	25
3.5.4 Nameplate Description.....	27
4 Check and Storage.....	29
4.1 Pre-acceptance Check.....	29
4.2 deliverables.....	29
4.3 Storage.....	31
5 Installation.....	32
5.1 Installation Requirements.....	32
5.1.1 Installation Environment Requirements.....	32
5.1.2 Installation Carrier Requirements.....	33
5.1.3 Installation Angle Requirements.....	33
5.1.4 Tool Requirements.....	34
5.2 Installing the Inverter.....	36
5.2.1 Moving the Inverter.....	36
5.2.2 Installing the Inverter.....	36
6 Electrical Connection.....	38
6.1 Connection Diagram.....	38

6.2 Safety Precautions	39
6.3 Connecting the PE cable	40
6.4 Connecting DC Input Cables (PV)	40
6.5 Connecting the Battery Cable	41
6.6 Connecting AC Cables	43
6.6.1 Connecting AC Cables (ON-GRID)	44
6.6.2 Connecting AC Cables(BACK-UP)	44
6.7 Communication Connection	45
6.7.1 Connecting Communication Cables	46
6.7.2 Connecting Meter or Battery Communication Cables (Optional)	47
6.7.3 Installing Communication Module (Optional)	49
7 Device Trial Run	51
7.1 Pre-power-on Check	51
7.2 Powering On the Device	51
8 System Commissioning	52
8.1 Indicator and Button Introduction	52
8.2 Download SEMS+ APP	53
8.3 Monitoring Power Station via SEMS+ WEB	54
8.4 Downloading and Installing SEMS+ App	55
9 Maintenance	57
9.1 Inverter Power Off	57
9.2 Removing the Inverter	57

9.3 Disposing of the Inverter.....	58
9.4 Inverter Fault.....	59
9.5 Routine Maintenance.....	126
10 technical parameter.....	128
10.1 Technical Parameters.....	128

# 1 Preface

This document primarily introduces the product information, installation and wiring, configuration and commissioning, troubleshooting, and maintenance of the inverter. Please read this manual carefully before installing and using this product to understand the product safety information and familiarize yourself with the product's functions and features. The document may be updated periodically; please obtain the latest version of the materials and more product information from the official website.

## 1.1 Applicable Model

This document applies to the following inverter models:



<b>model</b>	<b>Nominal output power</b>	<b>Nominal output voltage</b>
GW3600-EH	3.6kW	230/220V
GW5000-EH	5kW	
GW6000-EH	6kW	
GW3600N-EH	3.6kW	
GW5000N-EH	5kW	
GW6000N-EH	6kW	

## 1.2 Intended Personnel

Intended for use only by professionals who are familiar with local regulatory standards and electrical systems, have received specialized training, and possess thorough knowledge of this product.

## 1.3 Symbol Definition

To better use this manual, the following symbols are used to highlight relevant important information. Please read the symbols and their descriptions carefully.

 <b>DANGER</b>
Indicates a high potential danger that, if not avoided, will result in death or serious injury.
 <b>WARNING</b>
Indicates a moderate potential danger that, if not avoided, could result in death or serious injury.
 <b>CAUTION</b>
Indicates a low potential danger that, if not avoided, may result in moderate or minor injury.
<b>NOTICE</b>
Emphasizes and supplements the content, and may also provide tips or tricks for optimizing product use, helping you solve a problem or save time.

## 2 Safety Precautions

The safety precautions information contained in this document must always be followed when operating the equipment.

### WARNING

The inverter has been strictly designed and tested in compliance with safety regulations. However, as an electrical device, relevant safety instructions must be followed before performing any operations on the equipment. Improper operation may lead to serious injury or property damage.

### 2.1 General Safety

#### NOTICE

- Due to product version upgrades or other reasons, the document content will be updated periodically. Unless otherwise agreed, the document content cannot replace the safety precautions on the product label. All descriptions in the document are for guidance only.
- Please read this document carefully before installing the device to understand the product and its precautions.
- All operations on the device must be performed by professional and qualified electrical technicians who are familiar with the relevant standards and safety regulations of the project location.
- When operating the device, use insulated tools and wear personal protective equipment to ensure personal safety. When handling electronic components, wear anti-static gloves, anti-static wrist straps, anti-static clothing, etc., to protect the device from electrostatic damage.
- Unauthorized disassembly or modification may cause device damage, and such damage is not covered by the warranty.
- Device damage or personal injury caused by failure to install, use, or configure the device in accordance with the requirements of this document or the corresponding user manual is beyond the manufacturer's liability. For more product warranty information, please visit the official website:  
<https://en.goodwe.com/warrantyrelated.html>.

## 2.2 PV String Safety

### DANGER

Please use the DC terminal blocks provided with the box to connect the inverter DC cables. If other models of DC terminal blocks are used, it may lead to serious consequences, and any equipment damage caused by this is not within the manufacturer's responsibility.









### WARNING

- Ensure the component frame and bracket system are properly grounded.
- After completing the DC cable connections, ensure the connections are tight and secure, with no looseness.
- Use a multimeter to measure the positive and negative terminals of the DC cables to ensure correct polarity (no reverse connection) and that the voltage is within the allowable range.
- Do not connect the same PV string to multiple inverters, as this may cause inverter damage.

## 2.3 Inverter

### DANGER

- During inverter installation, please avoid putting weight on the bottom wiring terminals, as this may cause terminal damage.
- After inverter installation, the labels and warning signs on the enclosure must be clearly visible. Do not cover, alter, or damage them.
- The warning labels on the inverter enclosure are as follows:

No.	Symbol	Meaning
1		Potential hazard exists during equipment operation. Take protective measures when operating the equipment.
2		High voltage hazard. High voltage is present during equipment operation. Ensure the equipment is powered off before performing any operations.
3		The inverter surface is at high temperature. Do not touch during operation to avoid burns.
4		Delayed discharge. After powering off the device, wait for 5 minutes until it is fully discharged.
5		Read the product manual carefully before operating the equipment.
6		This equipment must not be disposed of as household waste. Dispose of it according to local laws and regulations, or return it to the manufacturer.
7		Grounding point.
8		CE certification mark.

## 2.4 Battery Safety

**WARNING**

- Batteries used with the inverter must be approved by the inverter manufacturer. The list of approved batteries can be obtained from the official website.
- Before installing the device, please carefully read the user manual corresponding to the battery to understand the product and safety matters. Operate strictly according to the requirements of the battery user manual.
- If the battery is fully discharged, please charge the battery strictly according to the user manual for the corresponding model.
- Battery current may be affected by some factors, such as: temperature, humidity, weather conditions, etc., which may cause current limiting and affect load capacity.
- If the battery cannot start, please contact the after-sales service center as soon as possible. Otherwise, the battery may be permanently damaged.
- Use a multimeter to measure the positive and negative poles of the DC cable to ensure correct polarity; and the voltage is within the allowable range.
- Do not connect the same battery bank to multiple inverters, as this may cause damage to the inverters.

## **2.5 personnel requirements**

## NOTICE

To ensure safety, compliance, and efficiency throughout the entire process of equipment transportation, installation, wiring, operation, and maintenance, all work must be performed by professionals or qualified personnel.

1. Professionals or qualified personnel include:
  - Personnel who have mastered knowledge of equipment working principles, system structure, risks and hazards, and have received professional operation training or possess extensive practical experience.
  - Personnel who have received relevant technical and safety training, possess certain operational experience, are aware of the potential dangers specific tasks may pose to themselves, and can take protective measures to minimize risks to themselves and others.
  - Qualified electrical technicians who meet the regulatory requirements of the country/region where the work is performed.
  - Personnel holding a degree in electrical engineering/an advanced diploma in electrical discipline or equivalent/professional qualifications in the electrical field, and possessing at least 2/3/4 years of experience in testing and supervision work using electrical equipment safety standards.
2. Personnel involved in special tasks such as electrical work, work at heights, and operation of special equipment must hold valid qualification certificates required by the location of the equipment.
3. Operation of medium-voltage equipment must be performed by certified high-voltage electricians.
4. Replacement of equipment and components is only permitted to be performed by authorized personnel.

## 2.6 EU Declaration of Conformity

### 2.6.1 Equipment with Wireless Communication Modules

GoodWe Technologies Co., Ltd. hereby declares that the Equipment with Wireless Communication Modules available for sale on the European market complies with the requirements of the following directives:

- Radio Equipment Directive 2014/53/EU (RED)
- Restrictions of Hazardous Substances Directive 2011/65/EU and (EU) 2015/863

(RoHS)

- Waste Electrical and Electronic Equipment 2012/19/EU
- Registration, Evaluation, Authorization and Restriction of Chemicals (EC) No 1907/2006 (REACH)

## **2.6.2 Devices without wireless communication functions**

GoodWe Technologies Co., Ltd. hereby declares that the devices without wireless communication functions sold in the European market meet the following directive requirements:

- Electromagnetic compatibility Directive 2014/30/EU (EMC)
- Electrical Apparatus Low Voltage Directive 2014/35/EU (LVD)
- Restrictions of Hazardous Substances Directive 2011/65/EU and (EU) 2015/863 (RoHS)
- Waste Electrical and Electronic Equipment 2012/19/EU
- Registration, Evaluation, Authorization and Restriction of Chemicals (EC) No 1907/2006 (REACH)

More EU Declaration of Conformity can be obtained from the official website:

<https://en.goodwe.com>.

# 3 Product Introduction

## 3.1 Product Overview

### Function Overview

Inverters in photovoltaic systems control and optimize energy flow through an integrated energy management system. The electricity generated in the photovoltaic system can be used for loads, stored in batteries, or fed back to the grid.

### Model Meaning



No.	Meaning	Description
1	Brand code	GW: GoodWe
2	Rated Power	3000: Rated power is 3000W 5000: Rated power is 5000W 6000: Rated power is 6000W
3	Product Feature	N: Boost current version
4	Series Code	EH: EH Series Single-phase Energy Storage Inverter

### 3.1.1 Feature Overview

In a photovoltaic system, the inverter controls and optimizes the energy flow through its integrated energy management system. It can supply the electricity generated by the photovoltaic system to loads, store it in batteries, or feed it into the grid.

### 3.1.2 Model Description

This document applies to the following inverter models:

- GW3600-EH
- GW5000-EH
- GW6000-EH
- GW3600N-EH
- GW5000N-EH
- GW6000N-EH

### Model Number Meaning

**GW3000N-EH**

1 2 3 4

No.	Meaning	Description
1	Brand code	GW: GoodWe
2	Rated Power	3000: Rated Power is 3000W 5000: Rated Power is 5000W 6000: Rated Power is 6000W
3	Product Feature	N: Boost Current Version
4	Series Code	EH: EH Series Single-phase Energy Storage Inverter

### 3.1.3 Supported Grid Types

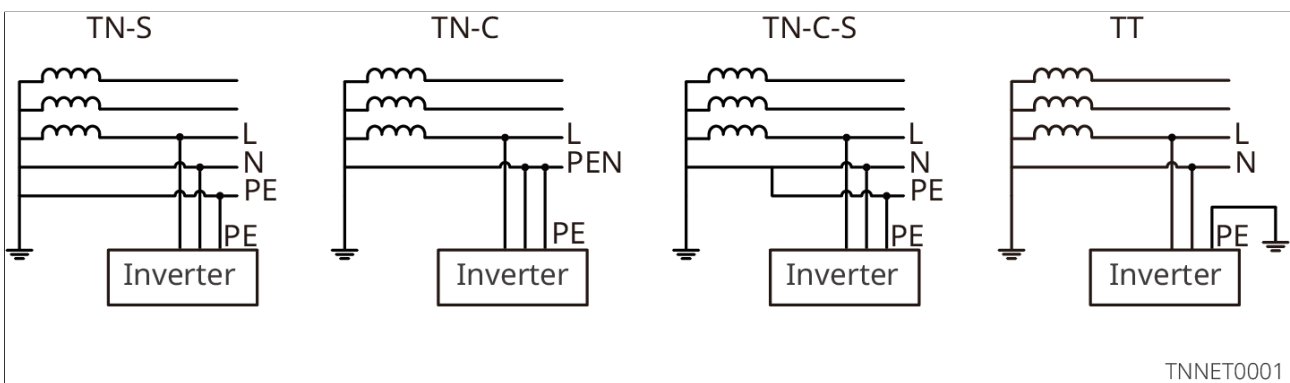

## 3.2 Application Scenarios



- The photovoltaic system is not suitable for connecting equipment that relies on stable power supply, such as life-sustaining medical devices. Please ensure that a system power failure will not cause personal injury.
- In the photovoltaic system, try to avoid using loads with high starting currents, such as high-power water pumps. Otherwise, the instantaneous power may be too high, leading to off-grid output failure.
- If the photovoltaic system is not configured with a battery, it is not recommended to use the BACK-UP function. The risk of system power usage caused by this will be beyond the warranty scope of the equipment manufacturer.
- The BACK-UP port does not support connecting autotransformers or isolation transformers.
- Battery current may be affected by factors such as temperature, Humidity, weather conditions, etc., which may cause battery current limiting and affect load capacity.
- The inverter has a UPS function with a switching time <10ms.
- When the inverter experiences a single overload protection event, it can restart automatically; if it occurs multiple times, the inverter restart time will be extended. If you need to restart the inverter as soon as possible, you can restart it immediately via the App.
- When the grid power fails, if the load capacity exceeds the inverter's rated power, the inverter's off-grid function will automatically shut down; to start it, large loads must be turned off to ensure the load power < the inverter's rated power.
- When the inverter is in off-grid mode, it can be used normally for common household loads, such as:
  - inductive load: Supports the use of a 1.5P non-inverter air conditioner. Connecting two or more non-inverter air conditioners may cause UPS mode instability.
  - Capacitive load: Total power  $\leq 0.6 \times$  inverter rated output power.

## Self-Consumption Solution

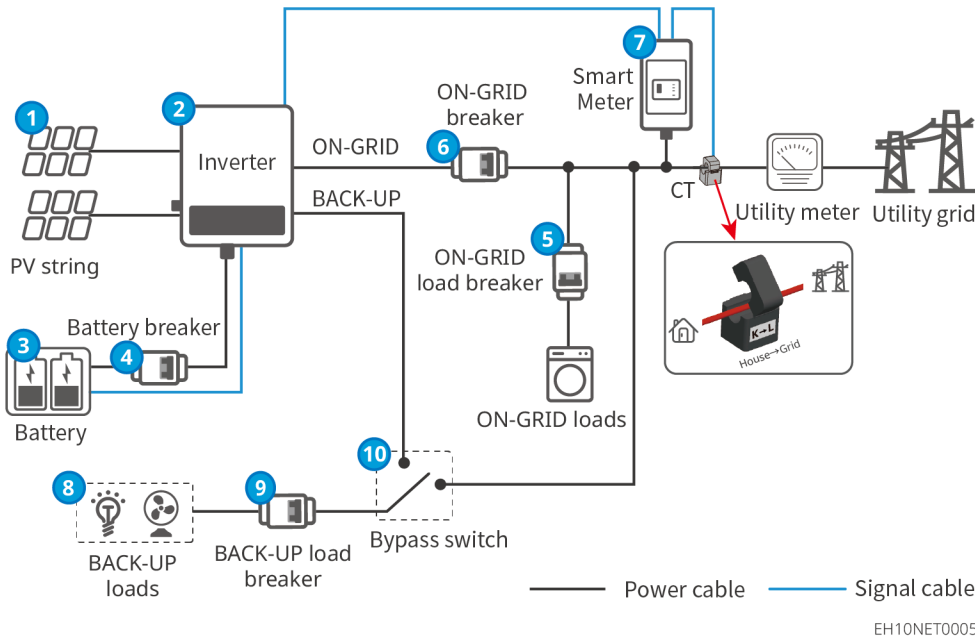

No.	Component	Description
1	PV String	A PV string is composed of photovoltaic modules connected in series.
2	Inverter	Supports EH series and EHPlus series inverters.
3	Battery	Selection should be based on the inverter and battery compatibility list. The approved battery list can be obtained from the official website.
4	Battery Switch	Recommended specifications: Rated Current $\geq 40A$ , Nominal Voltage $\geq 600V$ .
5	ON-GRID Load Breaker	Specification requirements should be determined based on the actual connected load.
6	ON-GRID Breaker	<ul style="list-style-type: none"> <li>Customer-provided AC circuit breaker. Recommended specifications: GW3600-EH, GW3600N-EH, GW5000-EH, GW5000N-EH: Rated Current <math>\geq 50A</math>, Nominal Voltage <math>\geq 230V</math>.</li> <li>GW6000-EH, GW6000N-EH: Rated Current <math>\geq 63A</math>, Nominal Voltage <math>&gt; 230V</math>.</li> </ul>

No.	Component	Description
7	Smart Meter	Purchase from the inverter manufacturer. Recommended models: GM3000/GM1000.
8	BACK-UP Loads	<ul style="list-style-type: none"> <li>• Supports connection of backup loads, such as loads requiring 24-hour power supply or other critical loads.</li> <li>• The BACK-UP port does not support connection of autotransformers or isolation transformers.</li> </ul>
9	BACK-UP Load Breaker	<p>Customer-provided AC circuit breaker. Recommended specifications:</p> <ul style="list-style-type: none"> <li>• GW3600-EH, GW3600N-EH, GW5000-EH, GW5000N-EH: Rated Current <math>\geq 50A</math>, Nominal Voltage <math>\geq 230V</math>.</li> <li>• GW6000-EH, GW6000N-EH: Rated Current <math>\geq 63A</math>, Nominal Voltage <math>\geq 230V</math>.</li> </ul>
10	Single-Pole Double-Throw Switch	<p>To ensure the BACK-UP port loads can continue operating during inverter maintenance shutdown, installation of a single-pole double-throw switch is recommended. Recommended specifications:</p> <ul style="list-style-type: none"> <li>• GW3600-EH, GW3600N-EH, GW5000-EH, GW5000N-EH: Rated Current <math>\geq 50A</math>, Nominal Voltage <math>\geq 230V</math>.</li> <li>• GW6000-EH, GW6000N-EH: Rated Current <math>\geq 63A</math>, Nominal Voltage <math>&gt; 230V</math>.</li> </ul>

## 3.3 Work Mode

### 3.3.1 System Operation Mode

#### Economic Mode

**NOTICE**

- The Economic Mode should only be selected in compliance with local laws and regulations, e.g., whether the grid is allowed to charge the battery. If not, please do not use this mode.
- It is recommended to use the Economic Mode in scenarios where there is a significant difference between peak and off-peak electricity prices.

- Daytime: When electricity rates are at peak, prioritize using the battery to power the load, and the remaining power can be sold to the grid.
- Nighttime: When electricity rates are at valley, you can set the grid to charge the battery at specific times, charging the battery.

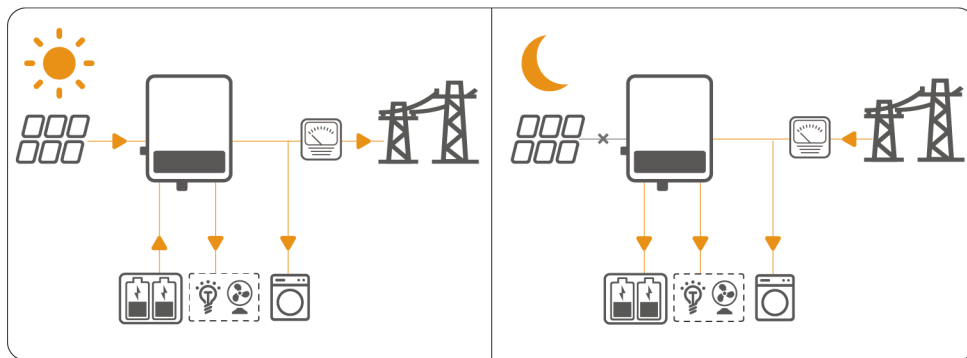

EH10NET0006

## Self-consumption Mode

### NOTICE

- Solar power generation prioritizes self-consumption, with excess electricity charging the battery; during nighttime when there is no solar power generation, use the battery to power the load; increase the self-consumption rate of the solar power system, saving electricity costs.
- Suitable for areas with high electricity prices and low or no subsidies for solar power feed-in tariffs.

Daytime:

- When the power generated by the photovoltaic system is sufficient, the power generated by the photovoltaic system is prioritized to supply the household load,

excess power charges the battery, and the remaining power is sold to the grid.

- When the power generated by the photovoltaic system is insufficient, prioritize using battery power to supply the load; if battery power is insufficient, then the grid supplies power to the load.

Nighttime:

- If the battery power is sufficient, the battery supplies power to the load. If the battery power is insufficient, then the grid supplies power to the load.

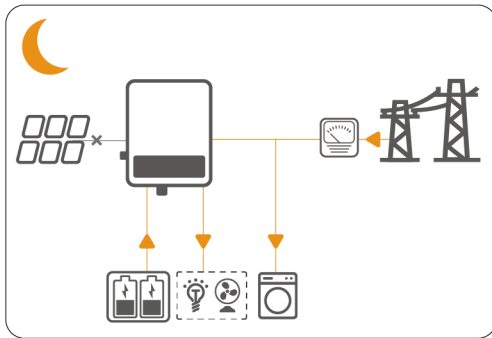
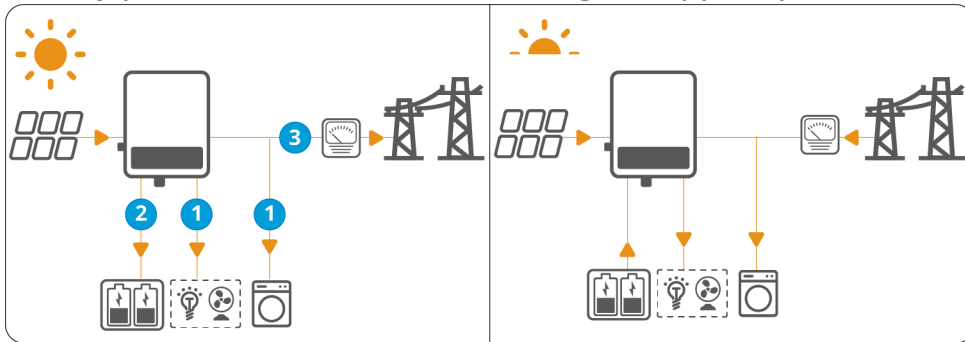

EH10NET0007

## Backup Mode

### NOTICE

- Backup mode is primarily suitable for scenarios with an unstable grid and critical loads. When grid power fails, the inverter switches to off-grid operation mode to supply power to the loads; when grid power is restored, the inverter switches its operation mode back to grid-tied.
- When the battery discharges to the cut-off SOC, it stops discharging. When there is sunlight the next day and the battery is charged to a certain level, the battery starts to supply power to the loads.

- When the power generated by the photovoltaic system is sufficient, the power generated by the photovoltaic system is prioritized to charge the battery, excess power is used for the load, and the remaining power is sold to the grid.
- When there is no PV power generation in the photovoltaic system:
  - When the grid is normal, the grid supplies power to the load. (If local laws and regulations do not allow the grid to charge the battery, do not use this scenario.)
  - When the grid is abnormal, the inverter enters off-grid mode operation, and the battery supplies power to the load.

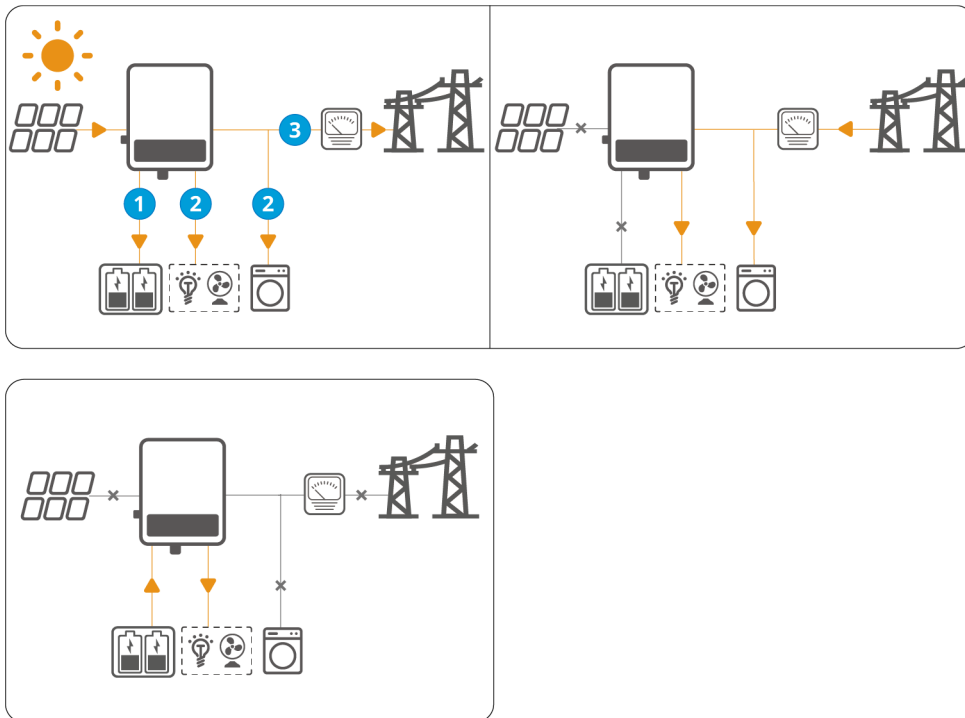

EH10NET0008

### 3.3.2 Inverter Operation Mode

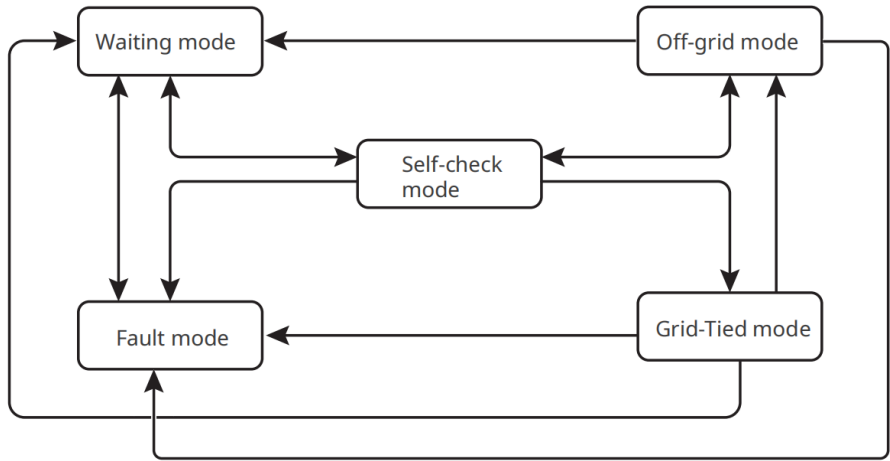

No.	Component	Description
1	Waiting mode	<p>Waiting stage after the machine is powered on</p> <ul style="list-style-type: none"> <li>When conditions are met, enter self-check mode</li> <li>If there is a fault, the inverter enters fault mode.</li> </ul>
2	Self-check mode	<p>Before the inverter starts, it continuously performs self-check, initialization, etc.</p> <ul style="list-style-type: none"> <li>If conditions are met, then enter On-grid mode, and the inverter starts and operates on-grid.</li> <li>If the grid is not detected, then enter off-grid mode, and the inverter operates off-grid; if the inverter does not have off-grid function, then enter waiting mode.</li> <li>If the self-check fails, then enter fault mode.</li> </ul>
3	On-grid mode	<p>The inverter operates normally on-grid.</p> <ul style="list-style-type: none"> <li>If it is detected that the grid does not exist, then enter off-grid working mode.</li> <li>If a fault is detected, then enter fault mode.</li> <li>If it is detected that grid conditions do not meet on-grid requirements, and the off-grid output function is not enabled, then enter waiting mode.</li> </ul>

No.	Component	Description
4	Off-grid mode	<p>When the grid is powered off, the inverter switches to off-grid mode and continues to supply power to the load.</p> <ul style="list-style-type: none"> <li>• If a fault is detected, then enter fault mode.</li> <li>• If it is detected that grid conditions do not meet on-grid requirements, and the off-grid output function is not enabled, then enter waiting mode.</li> <li>• If it is detected that grid conditions meet on-grid requirements, and the off-grid output function is enabled, then enter self-check mode.</li> </ul>
5	Fault mode	If a fault is detected, the inverter enters fault mode, and after the fault is cleared, it enters waiting mode.

## 3.4 Features

### Power Derating

To ensure the inverter operates safely, when the operating environment is not ideal, the inverter will automatically reduce output power.

The following are factors that may cause power derating. Please try to avoid them during use.

- Adverse environmental conditions, such as: direct sunlight, high temperature, etc.
- The output power percentage of the inverter has been set.
- Over-frequency load reduction.
- Input voltage value is high.
- Input current value is high.

### Earth Fault Alarm

The inverter reserves ports to implement the earth fault alarm function.

When an earth fault occurs, the inverter's LED fault indicator will light up. At the same time, the system will send a fault reminder email to the customer's preset mailbox.

To avoid missing fault prompts, please install the inverter in a position where the

indicator light is easily observed.

## 3.5 Appearance Description

### 3.5.1 Appearance Description

#### Appearance Introduction

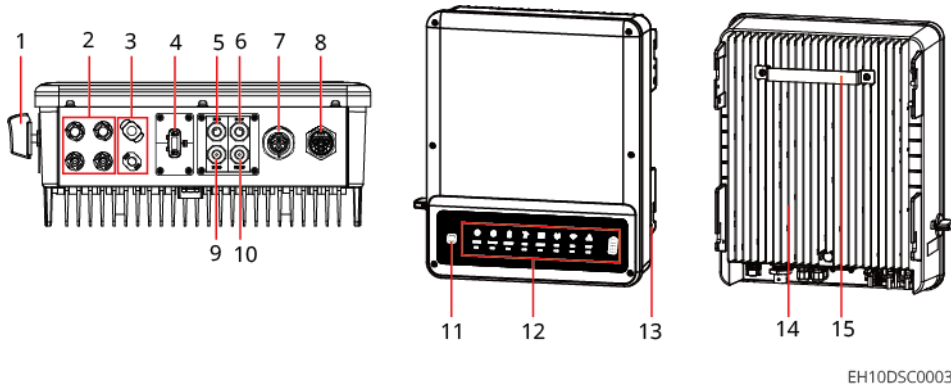

No.	Part	No.	Part
1	DC Switch [1]	2	PV DC Input Port (PV1/PV2)
3	Battery DC Input Port (BAT+/-)	4	Communication Module Interface (WiFi or LAN)
5	BMS Communication Port	6	METER Communication Port
7	Back-Up Output Port	8	On-Grid Output Port
9	DRED Communication Port	10	RS485 Communication Port
11	WiFi Reset Button	12	indicator
13	Grounding terminal	14	heat sink
15	Mounting Bracket	-	-

**[1]** If the inverter is not configured with a DC switch, an external DC circuit breaker is required. This DC circuit breaker should be certified by AU/NZ; comply with the AS60947.3:2018 standard; be classified as DC-PV2; and its protection level and characteristics should be suitable for specific conditions, such as outdoor use, direct sunlight, and installation on non-combustible material surfaces.

### 3.5.2 Dimensions

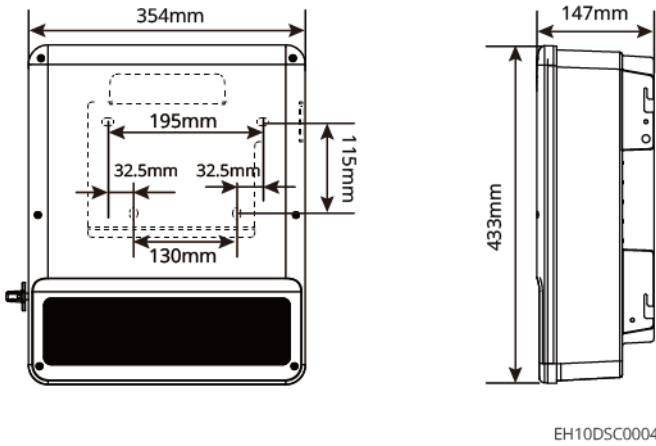



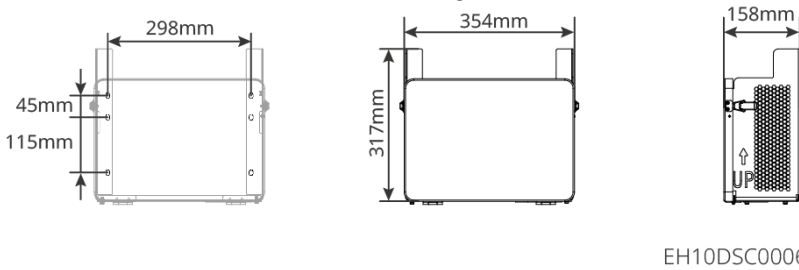

















#### Protective Cover (Australia only)



### 3.5.3 Indicator Light Instructions

indicator	Status	Description
SYSTEM		Solid on = System ready
		Single blink = System starting up
		Off = System not working
BACK-UP		Solid on = BACKUP function ready
		Off = BACKUP function disabled
BATTERY		Solid on = Battery charging
		Single blink = Battery discharging
		Two blinks = Battery low / Low SOC

indicator	Status	Description
		Off = Battery disconnected / Not working properly
GRID		Solid on = Grid connected, working normally
		Blinking = Grid normal, but not connected to the system
		Off = Grid not working properly
ENERGY		Solid on = buy power from the grid / Buying power
		Single blink = Supplying power to the grid / No buy or sell
		Two blinks = Supplying power to the grid / Export Energy
		Off = Not connected to grid, or system not working
COM		Solid on = BMS and meter communication normal
		Single blink = Meter communication normal, BMS disconnected
		Two blinks = BMS normal, meter communication disconnected
		Off = Both BMS and meter connections disconnected
WiFi		Solid on = WiFi normal, connected
		Single blink = WiFi resetting
		Two blinks = WiFi not connected to router
		Four blinks = WiFi server issue

indicator	Status	Description
		Off = WiFi not working properly
FAULT		Solid on = fault
		Single blink = BACKUP overload / Reduce load
		Four blinks = Meter detection result abnormal
		Off = No fault

### 3.5.4 Nameplate Description

The nameplate is for reference only, please refer to the actual product.

<b>GOODWE</b>	
<b>Product: Hybrid Inverter</b>	
<b>Model: ***</b>	
PV Input	UDC max: ***Vd.c.
	UMPP: ***Vd.c.
	Idc,max: ***Ad.c.
	ISC PV: ***Ad.c.
Battery	Ubatt: ***Vd.c., Li-Ion
	Ibatt,max(C/D): ***Ad.c.
On-grid	UAC: ***Va.c.
	fAC: ***Hz
	PAC: ***kW
	IAC,max(to grid): ***Aa.c.
	Sr(to grid): ***kVA
	Smax(to grid): ***kVA
	IAC(from grid): ***Aa.c.
	Sr(from grid): ***kVA
Smax(from grid): ***kVA	
Back-up	UAC,r: ***Va.c.
	fAC,r: ***Hz
	IAC,max: ***Aa.c.
	Sr: ***kVA
Smax: ***kVA	
P.F.: -1,0.8cap...0.8ind, Toperating: -35~60°C Non-isolated, IP66, Protective Class I, OVC DCII/ACIII	
S/N:	
GoodWe Technologies Co., Ltd. E-mail: service@goodwe.com No.90 Zijin Rd., New District, Suzhou, 215011, China S/N	

GW trademark, product type, and product model

Technical parameters

Safety symbols and certification marks

Contact information and serial number

# 4 Check and Storage

## 4.1 Inspection Before Signing

Before signing for the product, please carefully inspect the following:

1. Check if the outer packaging is damaged, such as deformation, holes, cracks, or other signs that might cause damage to the equipment inside the packaging box. If damaged, do not open the packaging and contact your dealer.
2. Check if the inverter model is correct. If it does not match, do not open the packaging and contact your dealer.
3. Check if the type and quantity of delivered items are correct, and if there is any damage to the appearance. If damaged, contact your dealer.



## 4.2 deliverables







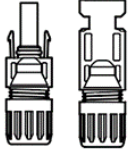
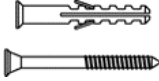

### WARNING

For electrical connections, please use the terminal blocks shipped with the unit. Damage caused by using incompatible connector models is not covered under warranty.

### NOTICE

1. The quantity of expansion screws, PV DC terminals, battery DC terminals, ON-GRID connector removal tool, and BACK-UP connector removal tool included with the package varies depending on the inverter configuration. Please refer to the actual contents.
2. Battery-Ready models do not include an energy meter. If required, please contact the manufacturer or distributor for purchase.
3. Applicable to Australia only.

Part	Quantity	Part	Quantity
	Inverter x 1		Backplate x 1

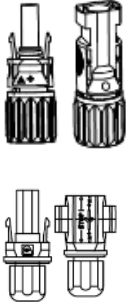
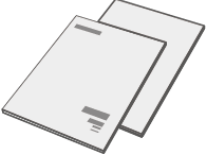
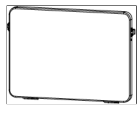
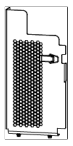
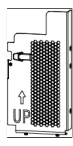
Part	Quantity	Part	Quantity
	PV connector x 2		expansion bolt x 4
	Grounding terminal x 1		smart dongle x 1
	ON-GRID AC connector x1		BACK-UP AC connector x1
	ON-GRID connector disassembly tool x1		BACK-UP connector disassembly tool x1
	Electric meter and accessories x N <sup>*2</sup>	 or	Battery connector x N <sup>*1</sup>
	Product documentation x 1		Front protective cover x 1 <sup>*3</sup>
	Left protective cover x 1 <sup>*3</sup>		Right protective cover x 1 <sup>*3</sup>

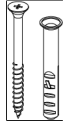
Part	Quantity	Part	Quantity
	Bottom cover x 1*3		Expansion bolt x 4*3

## 4.3 Storage

### NOTICE

The storage time of the inverter should not exceed two years. If the storage time exceeds two years, professional inspection and testing are required before putting it into use.

If the inverter is not put into use immediately, please store it according to the following requirements:

1. Ensure that the outer packaging box is not removed and the desiccant inside the box is not lost.
2. Ensure that the storage environment is clean, with appropriate temperature and humidity ranges, and no condensation.
3. Ensure that the stacking height and direction of the inverters are arranged according to the instructions on the packaging box label.
4. Ensure that there is no risk of tipping over after the inverters are stacked.
5. After long-term storage, the inverter must be inspected and confirmed by a professional before it can continue to be used.

# 5 Installation

## 5.1 Installation Requirements

### 5.1.1 Installation Environment Requirements

1. The device must not be installed in flammable, explosive, corrosive, or similar environments.
2. The installation location must be out of reach of children and avoid easily accessible positions. The device surface may become hot during operation to prevent burns.
3. Avoid installing near water pipes, cables, etc., inside walls to prevent hazards during drilling.
4. The inverter should be installed away from direct sunlight, rain, snow accumulation, etc. It is recommended to install in a sheltered location; a sunshade can be built if necessary.
5. The installation space must meet the device's ventilation, heat dissipation, and operational space requirements.
6. The device's protection rating is suitable for both indoor and outdoor installation. The ambient temperature and humidity must be within the suitable operating range.
7. The installation height should facilitate operation and maintenance, ensuring device indicator lights, all labels are easily visible, and wiring terminals are easy to operate.
8. The inverter installation altitude should be below the maximum operating altitude of 3000m.
9. Keep away from strong magnetic field environments to avoid electromagnetic interference. If there are radio or wireless communication devices below 30MHz near the installation location, please install the device according to the following requirements:
  - Add a multi-turn ferrite core on the inverter's DC input or AC output lines, or add a low-pass EMI filter.
  - Maintain a distance of over 30m between the inverter and the wireless electromagnetic interference device.

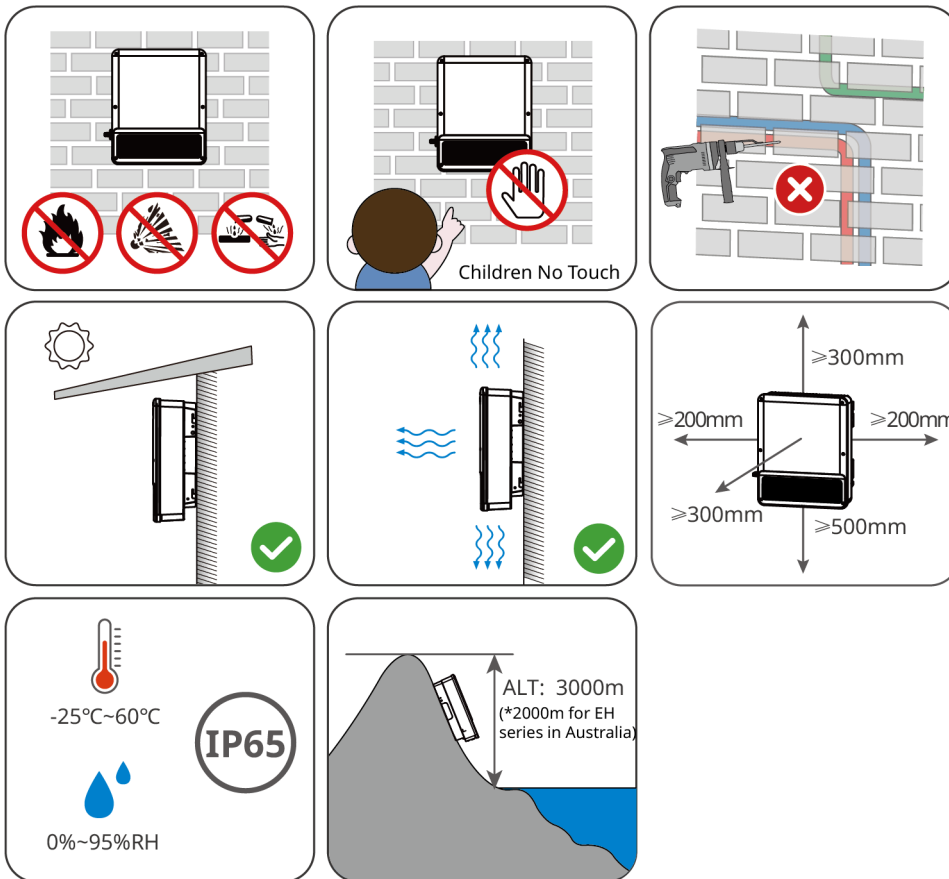

EH10INT0005

### 5.1.2 Installation Surface Requirements

- The installation surface must not be made of flammable materials and must possess fire-resistant properties.
- Ensure the installation surface is sturdy and reliable, capable of supporting the weight of the inverter.
- During operation, the equipment generates vibration. Do not install it on a surface with poor sound insulation to prevent noise from the operating equipment from disturbing residents in living areas.

### 5.1.3 Installation Angle Requirements

- Recommended inverter installation angle: vertical or tilted back  $\leq 15^\circ$ .
- Do not invert the inverter, tilt it forward, tilt it back beyond the angle, or install it horizontally.

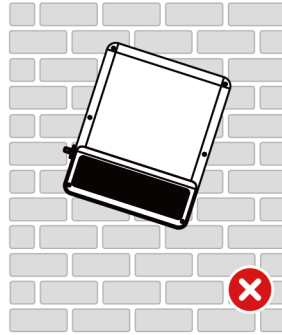
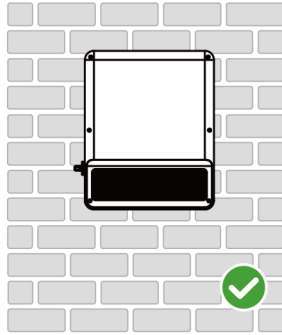
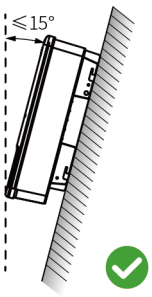



EH10INT0006

### 5.1.4 Tool Requirements

#### NOTICE

During installation, it is recommended to use the following installation tools. If necessary, other auxiliary tools can be used on-site.

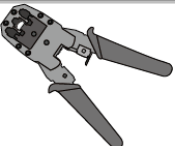
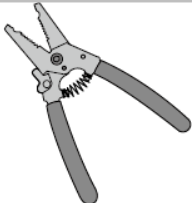
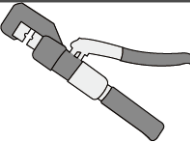
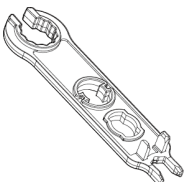
#### Installation Tools

Tool Type	Description	Tool Type	Description
	diagonal plier		RJ45 connector crimping tool
	wire stripper		YQK-70 hydraulic pliers
	Dianwei unlocking wrench		open-end wrench

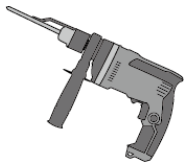
	MC4 unlocking wrench		hammer drill
	torque wrench M5, M3		rubber hammer
	socket wrench		marker pen
	multimeter Range $\leq 1100V$		heat shrink tubing
	heat gun		cable tie
	vacuum cleaner		Level bar

### personal protective equipment

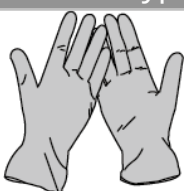
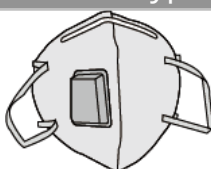
Tool Type	Description	Tool Type	Description
	Insulated gloves, protective gloves		Dust mask



goggle



Safety shoes

## 5.2 Installing the Inverter

### 5.2.1 Portable Inverter

#### CAUTION

- During operations such as transportation, handling, and installation, the laws, regulations, and relevant standard requirements of the country or region must be met.
- Before installation, the inverter needs to be moved to the installation site. To avoid personal injury or equipment damage during the moving process, please note the following:
  1. According to the equipment weight, assign an adequate number of persons to avoid the equipment exceeding the human weight-bearing capacity and causing injury.
  2. Please wear safety gloves to prevent injury.
  3. Ensure the equipment remains balanced during the moving process to avoid falling.

### 5.2.2 Installing the Inverter

#### NOTICE

- When drilling, ensure the drilling location avoids water pipes, cables, etc., inside the wall to prevent danger.
- When drilling, please wear safety goggles and a dust mask to avoid inhaling dust into the respiratory tract or getting it into the eyes.
- Ensure the inverter is installed securely to prevent it from falling and injuring people.
- Please prepare your own DC switch lock.

1. Place the back mounting plate horizontally on the wall, and use a marker pen to mark the drilling positions.
2. Use an impact drill with an 8mm diameter drill bit to drill holes, ensuring the hole depth is about 80mm.
3. Use expansion screws to fix the inverter back mounting plate bracket to the wall.
4. (Australia only) Install the DC switch lock, ensuring the DC switch is in the "OFF"

state during installation.

5. Hang the inverter on the back plate.

6. Secure the back plate and the inverter, ensuring the inverter is installed firmly.

7. Install the inverter anti-theft lock.

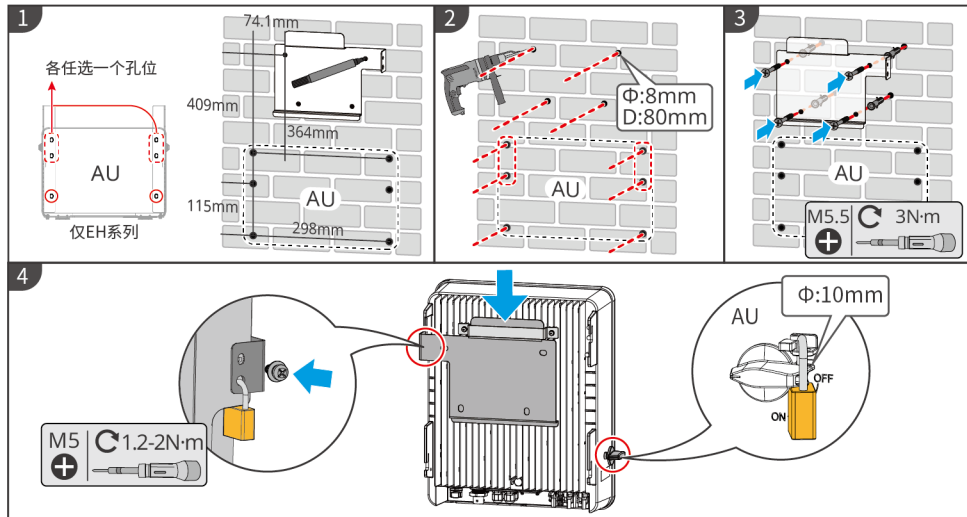

EH10INT0002

### Install the protective cover (Australia only)

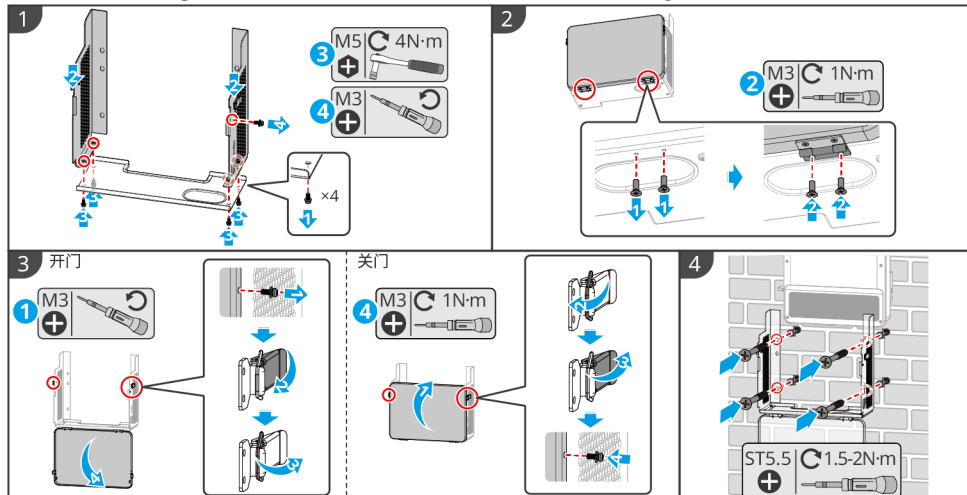

EH10INT0008

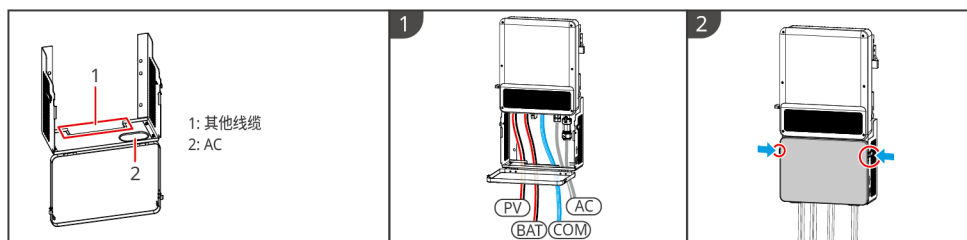

EH10ELC0018

# 6.1 Appliance Wiring Diagram

## NOTICE

- Depending on regional regulatory requirements, the wiring methods for the N and PE lines of the inverter's ON-GRID and BACK-UP ports differ. Please follow local regulations.
- The inverter's ON-GRID and BACK-UP AC ports have built-in relays. When the inverter is in off-grid mode, the built-in ON-GRID relay is open; when the inverter is in grid-connected operation mode, the built-in ON-GRID relay is closed.
- The BACK-UP AC port is live after the inverter is powered on. If maintenance is required on the BACK-UP Loads, please power down the inverter, otherwise electric shock may occur.

### N and PE lines connected together in the distribution box

## NOTICE

The following wiring method applies to regions such as Australia and New Zealand

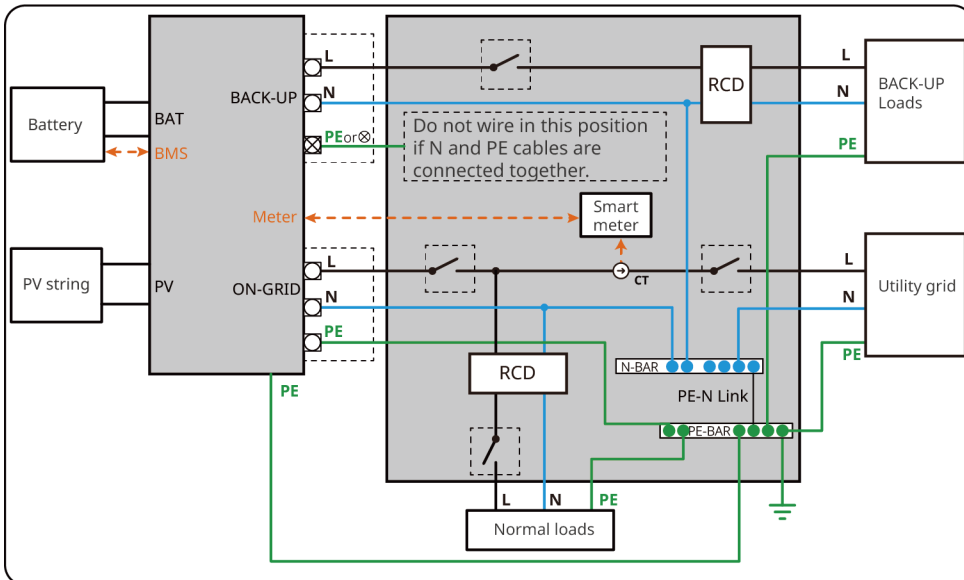

EH10NET0009

### N and PE lines wired separately in the distribution box

## NOTICE

For regions other than Australia, New Zealand, etc., the following wiring methods apply.

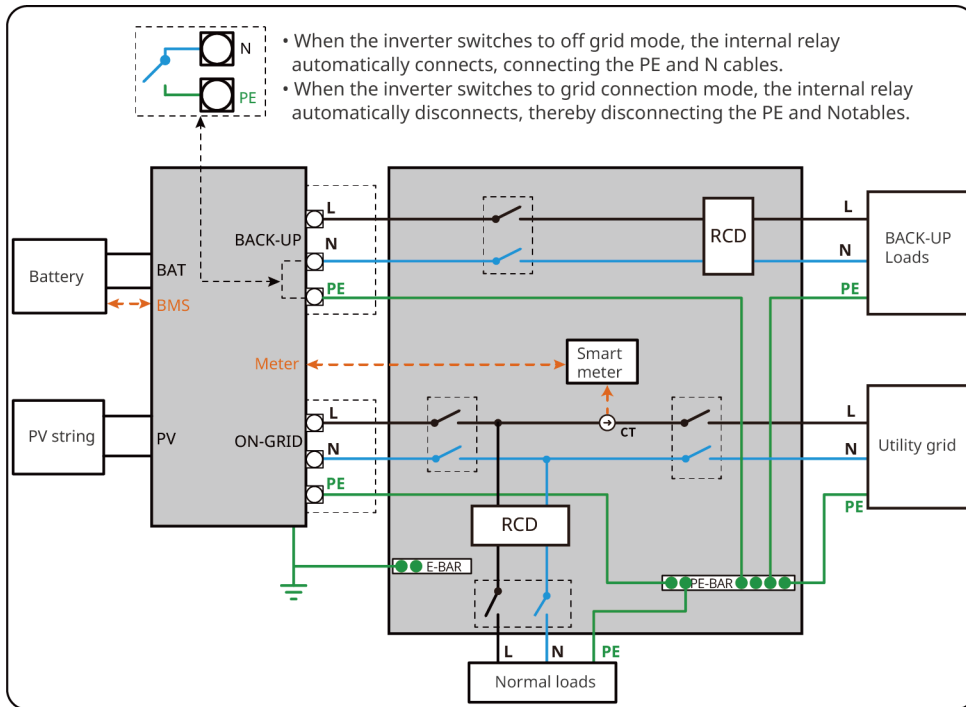

EH10NET0010

## 6.2 Safety Precautions



- All operations, cables, and component specifications used during electrical connection must comply with local laws and regulations.
- Before performing electrical connections, disconnect the inverter's DC switch and AC output switch to ensure the equipment is powered off. Live operation is strictly prohibited, as it may lead to dangers such as electric shock.
- Cables of the same type should be bundled together and arranged separately from different types of cables. Intertwining or cross-arrangement is prohibited.
- If the cable is subjected to excessive tension, it may result in poor connections. When wiring, leave a certain length of slack before connecting to the inverter's terminal ports.
- When crimping terminals, ensure the cable conductor is in full contact with the terminal. Do not crimp the cable insulation together with the terminal, as this may cause the equipment to malfunction, or lead to heating due to unreliable connections after operation, potentially damaging the inverter's terminal block.

NOTICE

- When performing electrical connections, wear personal protective equipment such as safety shoes, protective gloves, and insulating gloves as required.
- Only professionals are allowed to perform electrical connection-related operations.
- The cable colors in the diagrams in this document are for reference only; specific cable specifications must comply with local regulations.

## 6.3 Connecting the PE cable



**WARNING**

- The protective grounding of the chassis cannot replace the protective ground wire of the AC output port. When wiring, ensure the protective ground wires at both locations are reliably connected.
- For multiple inverters, ensure all inverter chassis protective grounding points are equipotentially connected.

To improve terminal corrosion resistance, it is recommended to apply silicone or paint on the exterior of the grounding terminal after the protective ground wire connection installation is complete for protection. Please prepare your own protective ground wire. Recommended specifications:

- Type: Outdoor single-core copper wire
- Conductor cross-sectional area: 4mm<sup>2</sup>

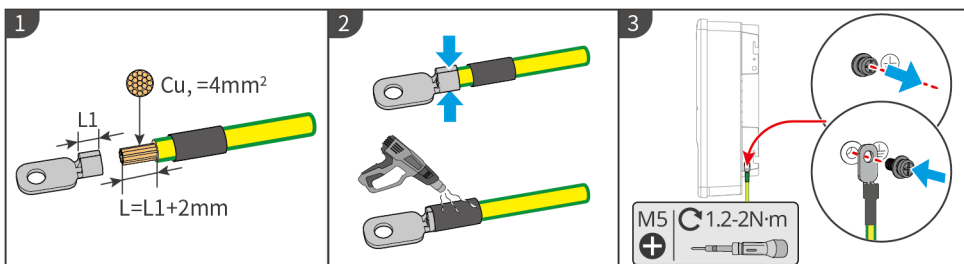

## 6.4 Connecting DC Input Lines (PV)



**DANGER**

- Do not connect the same PV string to multiple inverters, as this may cause inverter damage.
- Before connecting the PV string to the inverter, confirm the following information. Failure to do so may cause permanent damage to the inverter, and in severe cases, may lead to fire causing personal injury and property loss.
  1. Ensure the maximum short-circuit current and maximum input voltage for each MPPT are within the inverter's allowable range.
  2. Ensure the positive pole of the PV string is connected to the inverter's PV+, and the negative pole of the PV string is connected to the inverter's PV-.

**! WARNING**

PV string output does not support grounding. Before connecting the PV string to the inverter, ensure the minimum insulation resistance to ground of the PV string meets the minimum insulation impedance requirement  $R$  ( $R = \text{Max. Input Voltage} / 30\text{mA}$ ).

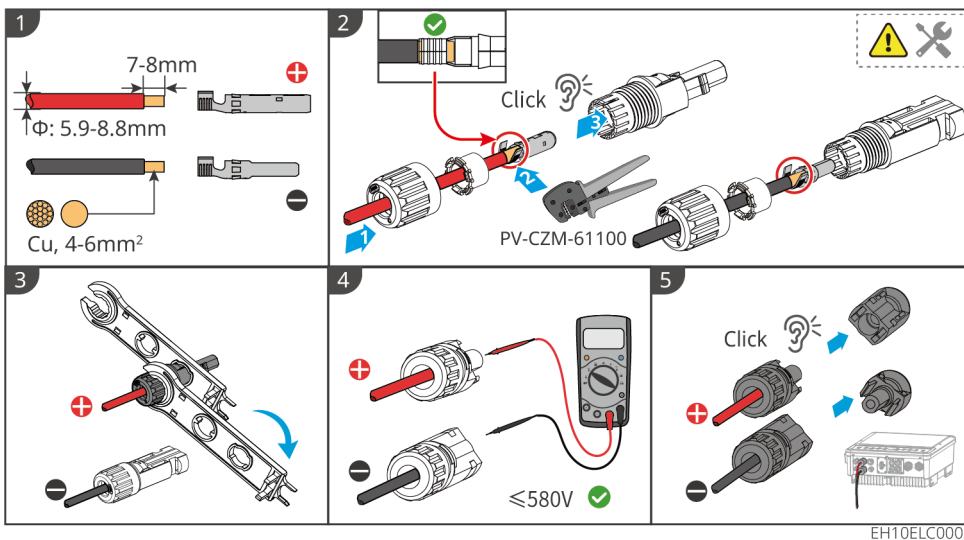

## 6.5 Connecting the Battery Cable

**NOTICE**

- For Battery-Ready models, if you need to use battery-related functions, please contact the manufacturer to activate the functionality first. Before activating the battery function, do not connect the battery to the inverter, otherwise the inverter will stop working.
- When the battery is not connected, please ensure the battery connection port is well sealed.

 **DANGER**

- Batteries used with the inverter must be approved by the inverter manufacturer. The approved battery list can be obtained from the official website.
- Battery short circuit may cause personal injury. The instantaneous high current from a short circuit can release a large amount of energy, potentially causing a fire.
- Before connecting the battery cables, ensure both the inverter and the battery are powered off, and all front-end and rear-end switches of the equipment are disconnected.
- Do not connect or disconnect battery cables while the inverter is running. Violation may lead to electric shock hazard.
- Do not connect the same battery bank to multiple inverters, as this may damage the inverters.
- Do not connect loads between the inverter and the battery.
- Use insulated tools when connecting battery cables to prevent accidental electric shock or causing a battery short circuit.
- Ensure the battery open-circuit voltage is within the allowable range of the inverter.

 **WARNING**

- When wiring, ensure the battery cables match the "BAT+", "BAT-", and ground terminals on the battery end exactly. Incorrect cable connection will cause device damage.
- Ensure the wire core is fully inserted into the terminal connection hole with no exposed part.
- Ensure the cable connections are tight, otherwise, during device operation, loose terminals may overheat and cause device damage.
- If the battery does not have a built-in DC circuit breaker, please connect an external DC circuit breaker. Recommended specification: 40A/600V.

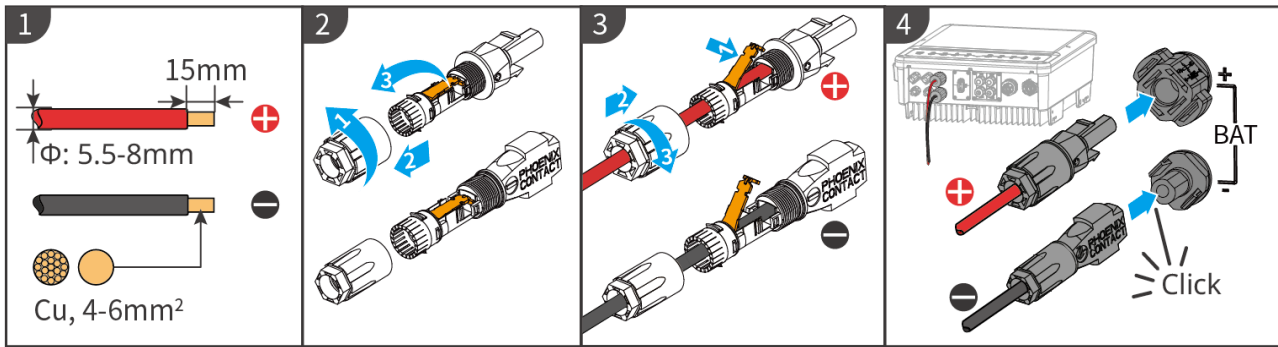

## 6.6 Connecting AC Cables

### NOTICE

- Each inverter must be equipped with an AC output switch. Multiple inverters cannot be connected to a single AC switch simultaneously. Do not connect loads between the inverter and the AC switch directly connected to the inverter.
- To ensure the inverter can safely disconnect from the grid in case of an abnormality, an AC switch must be installed on the AC side of the inverter. Select an appropriate AC switch according to local regulations.
- The protective earth (PE) conductor of the AC cable should be longer than the Neutral (N) and Line (L) conductors, so that the protective earth conductor is the last to bear strain if the AC cable slips out or is pulled out.
- The method for removing the AC terminal protective cover is subject to the actual product.

### ! WARNING

- When wiring, ensure the AC wires match the 'L', 'N', and 'PE' terminals exactly. Incorrect cable connection will cause equipment damage.
- Ensure the wire cores are fully inserted into the terminal wiring holes with no exposed parts.
- Ensure the cable connections are tight. Loose connections during equipment operation may cause terminal overheating and equipment damage.
- Even if the BACK-UP port is not in use, the BACK-UP connector from the accessory box must be installed on the BACK-UP port to ensure port protection and eliminate any risk of electric shock to personnel.

### ! WARNING

- Do not directly connect a generator to the AC side.
- The inverter has an integrated Residual Current Monitoring Unit (RCMU). When a leakage current exceeding the allowable value is detected, the inverter will quickly disconnect from the grid.
- The inverter's ON-GRID and BACK-UP AC ports have built-in relays. When the inverter is in off-grid mode, the built-in ON-GRID relay is open; when the inverter is in grid-connected operation mode, the built-in ON-GRID relay is closed.
- After the inverter is powered on, the BACK-UP AC port is live. If maintenance is required on the BACK-UP Loads, power off the inverter; otherwise, it may cause electric shock.
- Choose whether to connect a Residual Current Device (RCD) according to local laws and regulations. The inverter can be externally connected with a Type A RCD for protection when the DC component of the leakage current exceeds the limit. Recommended RCD specification:  $\geq 30\text{mA}$ .
- When the usage scenario does not require connecting AC cables, install connectors on the ON-GRID and BACK-UP ports to ensure they are protected and there is no risk of electric shock.

### 6.6.1 Connecting AC Cables (ON-GRID)

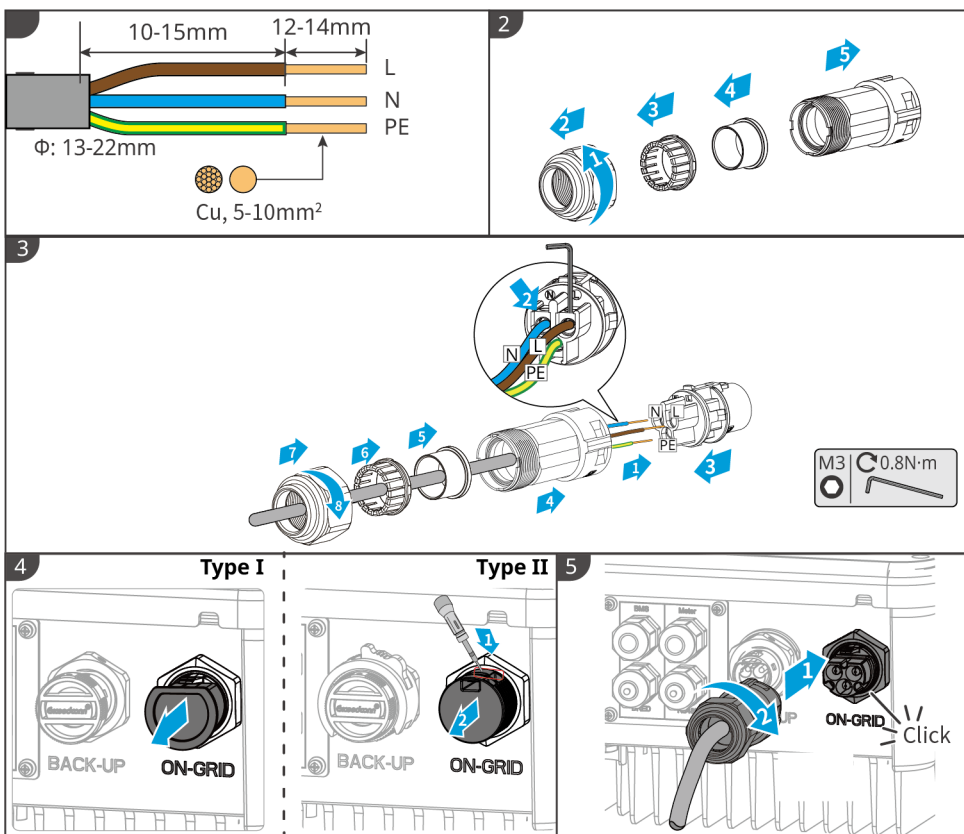

## 6.6.2 Connecting AC Cable (BACK-UP)

### NOTICE

- Ensure the protective grounding wire for BACK-UP is correctly and securely connected. Otherwise, the BACK-UP function may operate abnormally in the event of a grid fault.
- The BACK-UP side of the inverter must not be connected to the grid or other inverters.
- For maintenance convenience, it is recommended to install a Double-Pole Three-Throw (DP3T) switch on the BACK-UP side.

### ! WARNING

- If an AC circuit breaker is not used on the off-grid side, an electrical short circuit may damage the inverter, and the inverter's off-grid function cannot be turned off during grid connection.
- Recommended circuit breaker specification: 32A/230V.

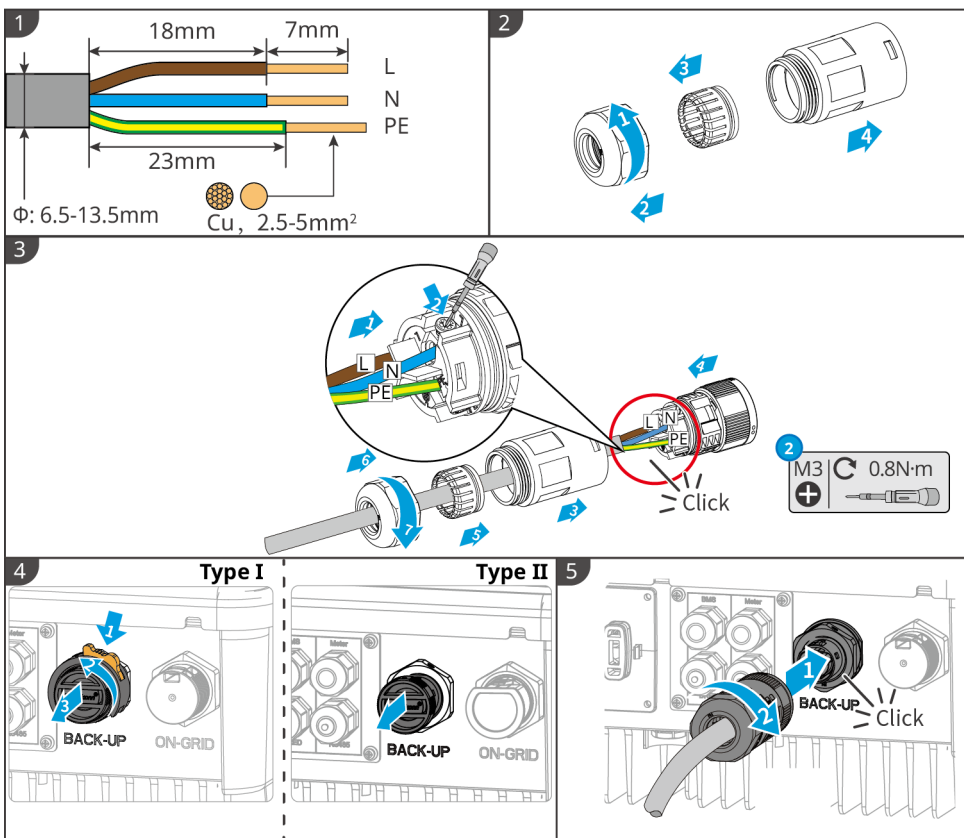

EH10ELC0006

## 6.7 Communication Connection

### 6.7.1 Connecting Communication Cables

#### NOTICE

- When connecting communication cables, ensure the port definitions match the device exactly. Route the cable away from interference sources and power lines to avoid affecting signal reception.
- The DRED function is applicable in Australia and New Zealand. When connecting the DRED communication cable, use the 6-pin communication terminal, and prepare your own communication cable and third-party DRED device.
- When connecting the remote shutdown communication cable, prepare your own communication cable and connect it to the 2-pin communication terminal.
- The communication terminal is equipped with a resistor. Remove and store the resistor properly before use.

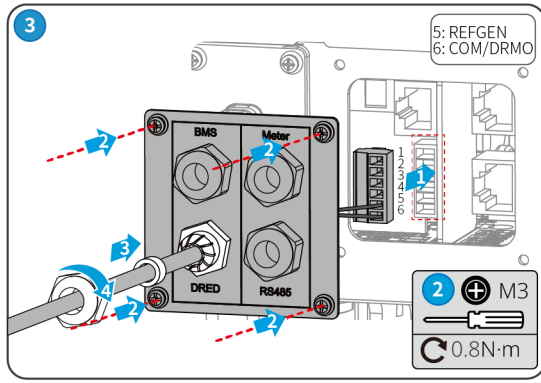
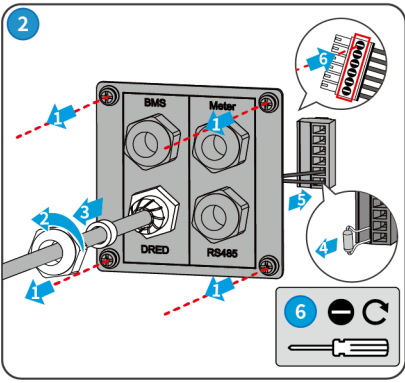
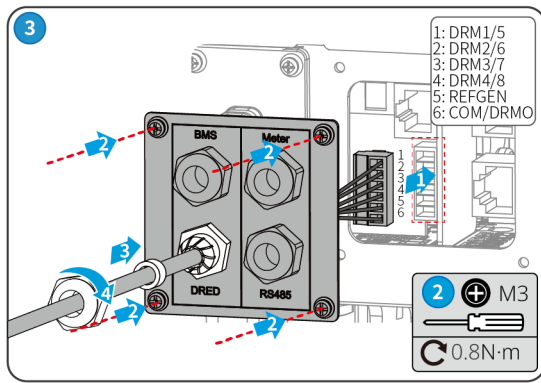
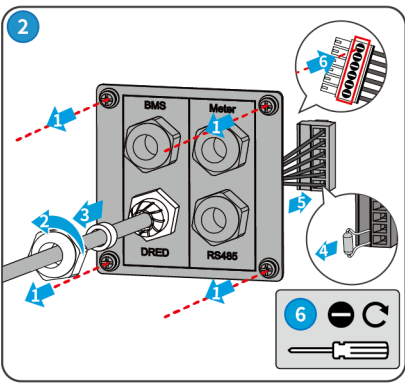
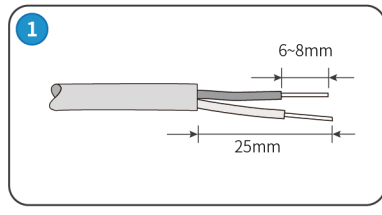
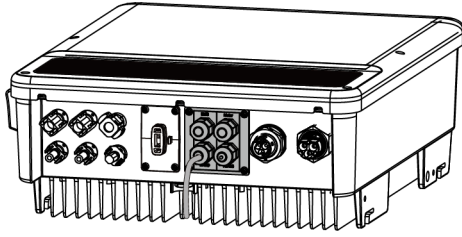

EH10ELC0013

## 6.7.2 Connecting Meter or Battery Communication Cable (Optional)

NOTICE

- [1] Supports connection to DNS G3 and MS G3 grid-tied inverters. Software version requirement: hybrid inverter ARM $\geq$ 33.357.
- The meter and CT are shipped with the box, and related parameters have been preset at the factory. Do not modify them.
- The inverter is shipped with a BMS battery communication cable and a communication cable between the meter and the inverter. For Battery Ready models, please prepare a BMS battery communication cable not exceeding 5 meters by yourself.
- The meter shipped with the box is for use with only one inverter. Do not connect one meter to multiple inverters. If you need to use multiple inverters, please consult the manufacturer to purchase meters separately.
- Please ensure that the CT connection direction is correct and connected to the correct phase line, such as CT1 connected to L1, CT2 connected to L2, CT3 connected to L3. For specific operations, please refer to the meter manual.
- Battery and meter communication support connection to standard RJ45 connectors. Port definitions are as follows:

No.	Color	BMS	Smart meter	RS485
1	Orange&White	485_A2	NC	485_A
2	Orange	NC	NC	485_B
3	Green&White	485_B2	485_B1	485_A
4	Blue	CAN_H	NC	NC
5	Blue&White	CAN_L	NC	NC
6	Green	NC	485_A1	485_B
7	Brown&White	NC	485_B1	NC
8	Brown	NC	485_A1	NC

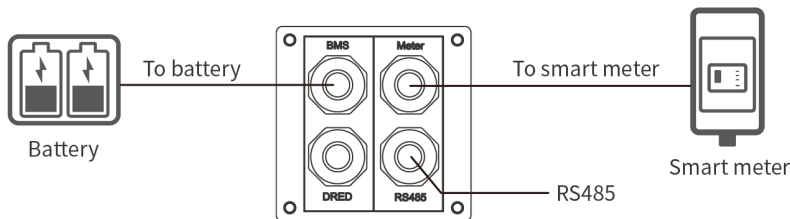
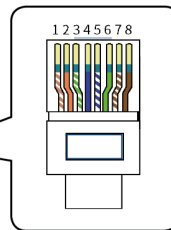

EH10ELC0014

## NOTICE

When paired with an electricity meter, it enables anti-backflow functionality. The specific networking solution is as follows.

### Anti-Backflow Networking Solution (Single-Phase Scenario)

When the load used is a single-phase load, EH and EH Plus series inverters can be paired with the GM1000 meter to achieve anti-backflow functionality.

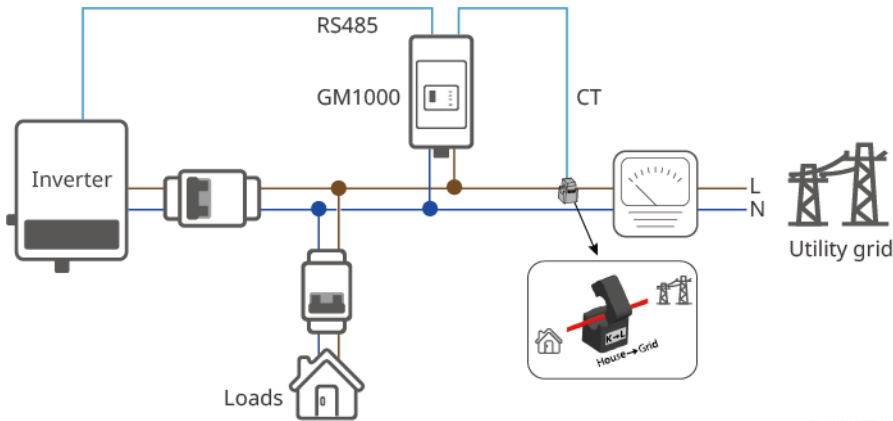

EH10NET0011

### Anti-Backflow Networking Solution (Split-Phase Scenario)

When the load used is a split-phase load, EH and EH Plus series inverters can be paired with the GM3000 meter to achieve anti-backflow functionality.

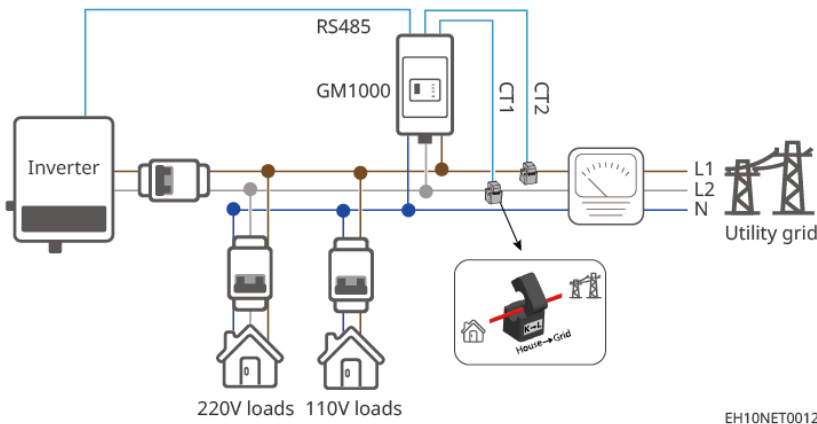

EH10NET0012

### 6.7.3 Installing Communication Module (Optional)

The inverter supports connecting to a mobile phone or WEB interface via Bluetooth, WiFi, LAN, or a 4G communication module to set device parameters, view device operation information and error messages, and stay informed about the system status in a timely manner.

WiFi Kit, Wi-Fi/LAN Kit module: Optional.

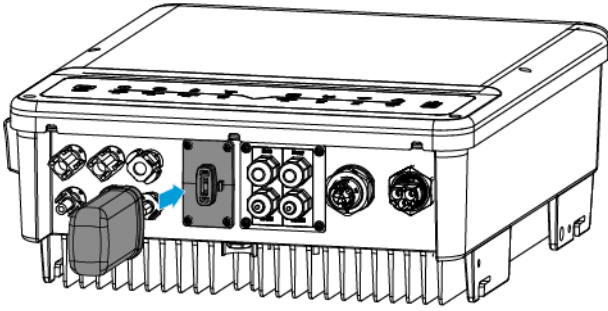

EH10ELC0015

### **Resetting and Reloading WiFi**

Briefly press the WiFi reset button, and the WiFi indicator will blink for a few seconds until the WiFi module restarts.

Long-press the WiFi reset button, and the WiFi indicator will flash alternately until the WiFi is reconfigured or the module is restored to factory settings.

If you encounter the following WiFi function issues, you can reset or reload the WiFi module.

- Unable to connect to the PV Master app;
- Cannot find the Solar-WiFi signal;
- Configuration issues such as Wi-Fi disconnecting from the network.

# 7 Equipment Trial Run

## 7.1 Pre-power-on Check















No.	Inspection Item
1	The inverter is securely installed, the location facilitates operation and maintenance, the installation space allows for ventilation and heat dissipation, and the installation environment is clean and tidy.
2	The PE cable, DC input cables, AC output cables, and communication cables are connected correctly and securely.
3	Cable bundling meets wiring requirements, is reasonably distributed, and shows no damage.
4	Ensure unused cable entry holes are fitted with waterproof caps.
5	The voltage and frequency at the inverter's grid connection point meet the grid connection requirements.















## 7.2 Powering On the Device

1. Close the AC circuit breaker on the inverter's ON-GRID side.
2. Close the AC circuit breaker on the inverter's BACK-UP side.
3. Close the energy storage circuit breaker between the inverter and the battery.
4. Close the DC switch of the inverter.

# 8 System Commissioning

## 8.1 Indicator Lights and Buttons Introduction

Indicator	Status	Description
SYSTEM		Solid on = System ready
		Single blink = System starting up
		Off = System not operating
BACK-UP		Solid on = BACKUP function ready
		Off = BACKUP function disabled
BATTERY		Solid on = Battery charging
		Single blink = Battery discharging
		Double blink = Battery low / Low SOC
		Off = Battery disconnected / Not functioning properly
GRID		Solid on = Grid connected, operating normally
		Blinking = Grid normal, but not connected to the system
		Off = Grid not functioning properly
ENERGY		Solid on = buy power from the grid / Buying power
		Single blink = Supplying power to the grid / No buy/sell
		Double blink = Supplying power to the grid / Export Energy

Indicator	Status	Description
		Off = Not connected to the grid, or system not operating
COM		Solid on = BMS and meter communication normal
		Single blink = Meter communication normal, BMS disconnected
		Double blink = BMS normal, meter communication disconnected
		Off = Both BMS and meter connections disconnected
WiFi		Solid on = WiFi normal, connected
		Single blink = WiFi resetting
		Double blink = WiFi not connected to router
		Quadruple blink = WiFi server issue
		Off = WiFi not functioning properly
FAULT		Solid on = fault
		Single blink = BACKUP overload / Reduce load
		Quadruple blink = Meter detection result abnormal
		Off = No fault

## 8.2 Download SEMS+ APP

### Phone Requirements:

- Operating System: Android 6.0 or above, iOS 13.0 or above.

- The phone must have a web browser and be able to connect to the Internet.
- The phone must support WLAN/Bluetooth functionality.

### Download Methods:

#### Method 1:

Search for SEMS+ in Google Play (Android) or the App Store (iOS) to download and install.



#### Method 2:

Scan the QR code below to download and install.



## 8.3 Power Plant Monitoring via SEMS+ WEB

SEMS+ WEB is a monitoring platform that communicates via WiFi or LAN. The following are the common functions of SEMS+ WEB:

1. Manage organization or user information, etc.
2. Add and monitor power plant information, etc.
3. Maintain equipment.

For detailed functions, please refer to the [SEMS+ WEB User Manual](#).



《SEMS+ WEB User Manual》

## 8.4 Download and Install SEMS+ App

### Phone Requirements:

- Operating system requirements: Android 7.0 and above, iOS 15.1 and above.
- The phone supports a web browser and connects to the Internet.
- The phone supports WLAN/Bluetooth functionality.

### Download Methods:

#### Method 1:

Search for SEMS+ in Google Play, App Store, Huawei, Honor, Xiaomi, OPPO, and vivo app stores to download and install.



#### Method 2:

Scan the QR code below to download and install.

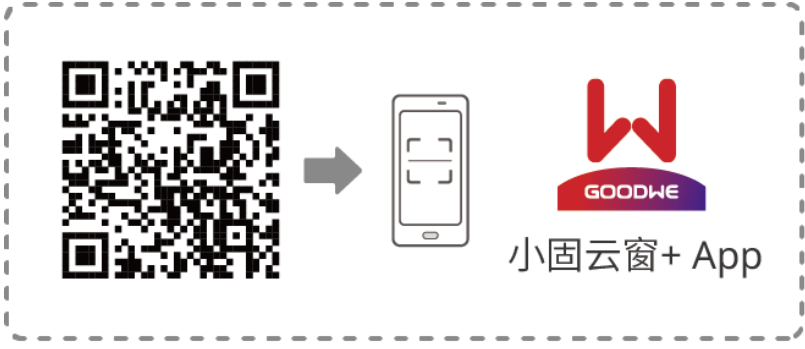

SEMS0164

# 9 Maintenance

## 9.1 Inverter Shutdown



- When performing operation and maintenance on the inverter, please de-energize the inverter. Operating the equipment while energized may cause inverter damage or electric shock DANGER.
- After the inverter is powered off, internal components require some time to discharge. Please wait until the equipment is completely discharged according to the time requirements on the label.

1. Disconnect the AC circuit breaker on the ON-GRID side of the inverter.
2. Disconnect the AC circuit breaker on the BACK-UP side of the inverter.
3. Disconnect the energy storage circuit breaker between the inverter and the battery.
4. Disconnect the DC switch of the inverter.

## 9.2 Inverter Removal



- Ensure the inverter is powered off.
- When operating the inverter, please wear personal protective equipment.

1. Disconnect all electrical connections of the inverter, including: DC cables, AC cables, Communication cable, smart dongle, PE cable.
2. Remove the inverter from the back mounting plate.
3. Remove the back mounting plate.
4. Store the inverter properly. If the inverter is to be put into service again later, ensure the storage conditions meet the requirements.

### Removing ON-GRID AC Terminals

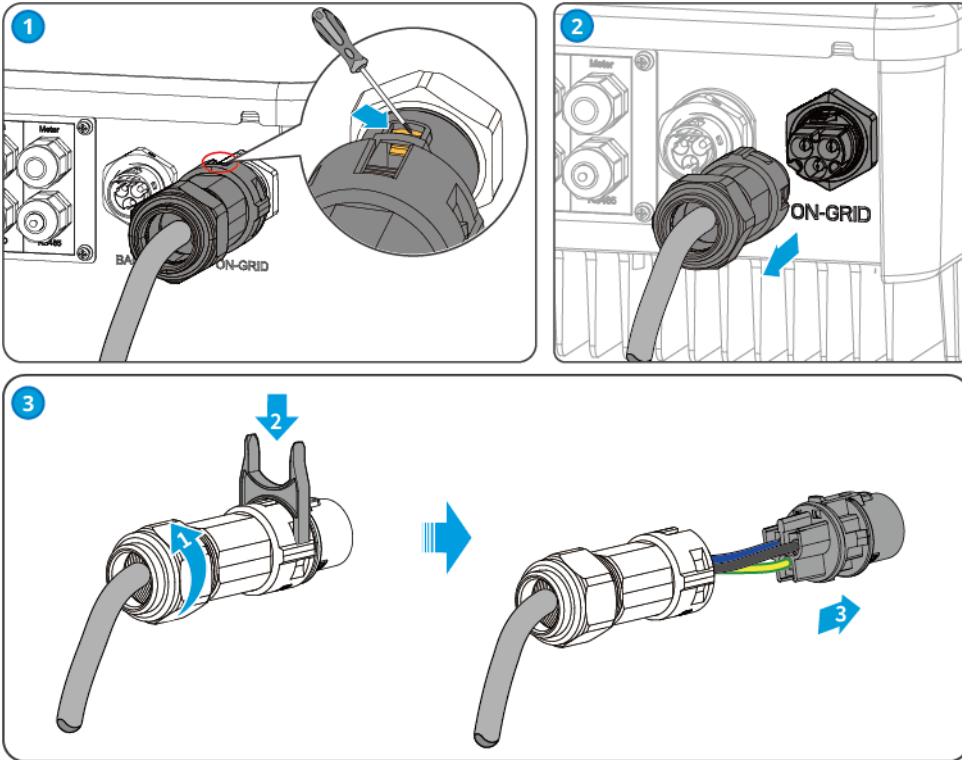

EH10ELC0016

### Removing BACK-UP AC Terminals

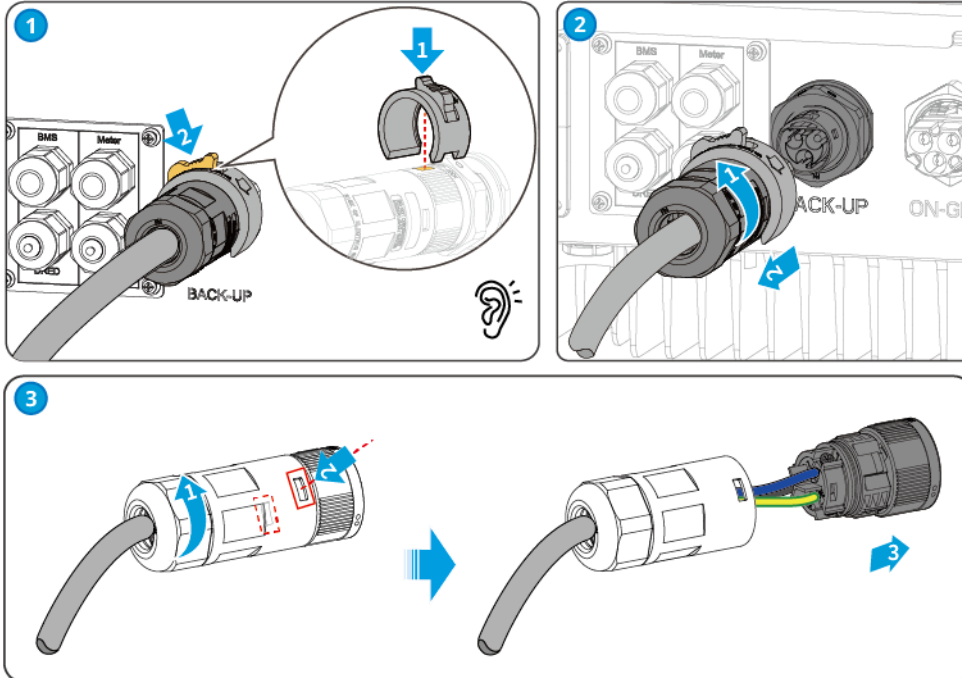

EH10ELC0017

## 9.3 Scrapped Inverter

When the inverter can no longer be used and needs to be scrapped, please dispose of it according to the electrical waste disposal requirements of the regulations in the country/region where the inverter is located. Do not dispose of the inverter as general household waste.

## 9.4 Inverter Fault

Fault Code	Fault Name	Fault Cause	Troubleshooting Suggestions
F01	Grid Power Outage	1. Grid power outage. 2. AC line or AC switch is disconnected.	1. The alarm will disappear automatically after grid power supply is restored. 2. Check whether the AC line or AC switch is disconnected.

Fault Code	Fault Name	Fault Cause	Troubleshooting Suggestions
F02	Grid Overvoltage Protection	Grid voltage is higher than the allowable range, or the duration of high voltage exceeds the HVRT setting.	<p>1. If it occurs occasionally, it may be a short-term grid anomaly. The inverter will resume normal operation after detecting a normal grid, requiring no manual intervention.</p> <p>2. If it occurs frequently, check whether the grid voltage is within the allowable range.</p> <ul style="list-style-type: none"> <li>• If the grid voltage is outside the allowable range, contact the local power operator.</li> <li>• If the grid voltage is within the allowable range, after obtaining consent from the local power operator, modify the inverter's grid overvoltage protection point, HVRT, or disable the grid overvoltage protection function.</li> </ul> <p>3. If it cannot be restored for a long time, check whether the AC-side circuit breaker and output cables are properly connected.</p>

Fault Code	Fault Name	Fault Cause	Troubleshooting Suggestions
F03	Grid Undervoltage Protection	Grid voltage is lower than the allowable range, or the duration of low voltage exceeds the LVRT setting.	<p>1. If it occurs occasionally, it may be a short-term grid anomaly. The inverter will resume normal operation after detecting a normal grid, requiring no manual intervention.</p> <p>2. If it occurs frequently, check whether the grid voltage is within the allowable range.</p> <ul style="list-style-type: none"> <li>• If the grid voltage is outside the allowable range, contact the local power operator.</li> <li>• If the grid voltage is within the allowable range, after obtaining consent from the local power operator, modify the inverter's grid undervoltage protection point, LVRT, or disable the grid undervoltage protection function.</li> </ul> <p>3. If it cannot be restored for a long time, check whether the AC-side circuit breaker and output cables are properly connected.</p>

Fault Code	Fault Name	Fault Cause	Troubleshooting Suggestions
F04	Grid Rapid Overvoltage Protection	Abnormal grid voltage detection or ultra-high voltage triggers the fault.	<p>1. If it occurs occasionally, it may be a short-term grid anomaly. The inverter will resume normal operation after detecting a normal grid, requiring no manual intervention.</p> <p>2. If it occurs frequently, check whether the grid voltage is within the allowable range.</p> <ul style="list-style-type: none"> <li>• If the grid voltage is outside the allowable range, contact the local power operator.</li> <li>• If the grid voltage is within the allowable range, after obtaining consent from the local power operator, modify the inverter's grid undervoltage protection point, LVRT, or disable the grid undervoltage protection function.</li> </ul> <p>3. If it cannot be restored for a long time, check whether the AC-side circuit breaker and output cables are properly connected.</p>

Fault Code	Fault Name	Fault Cause	Troubleshooting Suggestions
F05	10min Overvoltage Protection	The moving average of grid voltage within 10min exceeds the safety regulation range.	<ol style="list-style-type: none"> <li>1. If it occurs occasionally, it may be a short-term grid anomaly. The inverter will resume normal operation after detecting a normal grid, requiring no manual intervention.</li> <li>2. Check if the grid voltage has been operating at a high voltage for a long time. If it occurs frequently, check whether the grid voltage is within the allowable range. <ul style="list-style-type: none"> <li>• If the grid voltage is outside the allowable range, contact the local power operator.</li> <li>• If the grid voltage is within the allowable range, after obtaining consent from the local power operator, modify the grid 10min overvoltage protection point.</li> </ul> </li> </ol>

Fault Code	Fault Name	Fault Cause	Troubleshooting Suggestions
F06	Grid Overfrequency	Grid anomaly: The actual grid frequency is higher than the local grid standard requirement.	<p>1. If it occurs occasionally, it may be a short-term grid anomaly. The inverter will resume normal operation after detecting a normal grid, requiring no manual intervention.</p> <p>2. If it occurs frequently, check whether the grid frequency is within the allowable range.</p> <ul style="list-style-type: none"> <li>• If the grid frequency is outside the allowable range, contact the local power operator.</li> <li>• If the grid frequency is within the allowable range, after obtaining consent from the local power operator, modify the grid overfrequency protection point.</li> </ul>

Fault Code	Fault Name	Fault Cause	Troubleshooting Suggestions
F07	Grid Underfrequency	Grid anomaly: The actual grid frequency is lower than the local grid standard requirement.	<p>1. If it occurs occasionally, it may be a short-term grid anomaly. The inverter will resume normal operation after detecting a normal grid, requiring no manual intervention.</p> <p>2. If it occurs frequently, check whether the grid frequency is within the allowable range.</p> <ul style="list-style-type: none"> <li>• If the grid frequency is outside the allowable range, contact the local power operator.</li> <li>• If the grid frequency is within the allowable range, after obtaining consent from the local power operator, modify the grid overfrequency protection point.</li> </ul>

Fault Code	Fault Name	Fault Cause	Troubleshooting Suggestions
F08	Grid Frequency Instability	Grid anomaly: The rate of change of the actual grid frequency does not comply with the local grid standard.	<p>1. If it occurs occasionally, it may be a short-term grid anomaly. The inverter will resume normal operation after detecting a normal grid, requiring no manual intervention.</p> <p>2. If it occurs frequently, check whether the grid frequency is within the allowable range.</p> <ul style="list-style-type: none"> <li>• If the grid frequency is outside the allowable range, contact the local power operator.</li> <li>• If the grid frequency is within the allowable range, contact your dealer or after-sales service center.</li> </ul>

Fault Code	Fault Name	Fault Cause	Troubleshooting Suggestions
F163	Grid Phase Instability	Grid anomaly: The rate of change of the grid voltage phase does not comply with the local grid standard.	<p>1. If it occurs occasionally, it may be a short-term grid anomaly. The inverter will resume normal operation after detecting a normal grid, requiring no manual intervention.</p> <p>2. If it occurs frequently, check whether the grid frequency is within the allowable range.</p> <ul style="list-style-type: none"> <li>• If the grid frequency is outside the allowable range, contact the local power operator.</li> <li>• If the grid frequency is within the allowable range, contact your dealer or after-sales service center.</li> </ul>

Fault Code	Fault Name	Fault Cause	Troubleshooting Suggestions
F09	Anti-islanding Protection	The grid has been disconnected. Grid voltage is maintained due to the presence of load. Grid-tie is stopped according to safety protection requirements.	<p>1. If it occurs occasionally, it may be a short-term grid anomaly. The inverter will resume normal operation after detecting a normal grid, requiring no manual intervention.</p> <p>2. If it occurs frequently, check whether the grid frequency is within the allowable range.</p> <ul style="list-style-type: none"> <li>• If the grid frequency is outside the allowable range, contact the local power operator.</li> <li>• If the grid frequency is within the allowable range, contact your dealer or after-sales service center.</li> </ul>
F10	LVRT Undervoltage Fault	Grid anomaly: The duration of abnormal grid voltage exceeds the time specified for HVRT/LVRT.	<p>1. If it occurs occasionally, it may be a short-term grid anomaly. The inverter will resume normal operation after detecting a normal grid, requiring no manual intervention.</p>
F11	HVRT Overvoltage	Grid anomaly: The duration of abnormal grid voltage exceeds the time specified for HVRT/LVRT.	<p>2. If it occurs frequently, check whether the grid voltage and frequency are within the allowable range and stable. If not, contact the local power operator; if yes, contact your dealer or after-sales service center.</p>

Fault Code	Fault Name	Fault Cause	Troubleshooting Suggestions
F43	Grid Waveform Abnormal	Grid anomaly: Abnormal grid voltage detection triggers the fault.	<ol style="list-style-type: none"> <li>1. If it occurs occasionally, it may be a short-term grid anomaly. The inverter will resume normal operation after detecting a normal grid, requiring no manual intervention.</li> <li>2. If it occurs frequently, check whether the grid voltage and frequency are within the allowable range and stable. If not, contact the local power operator; if yes, contact your dealer or after-sales service center.</li> </ol>
F44	Grid Phase Loss	Grid anomaly: There is a single-phase voltage dip in the grid.	
F45	Grid Voltage Imbalance	Excessive difference in grid phase voltages.	
F46	Grid Phase Sequence Failure	Abnormal inverter and grid wiring: wiring is not in positive sequence	<ol style="list-style-type: none"> <li>1. Check if the wiring between the inverter and the grid is in the correct positive sequence. The fault will clear automatically after correct wiring (e.g., swapping any two live wires).</li> <li>2. If the fault persists despite correct wiring, please contact the dealer or after-sales service center.</li> </ol>
F47	Grid Rapid Shutdown Protection	Quickly shuts down output after detecting a grid power outage condition	<ol style="list-style-type: none"> <li>1. The fault clears automatically after grid power is restored.</li> </ol>
F48	Grid Neutral Wire Loss	Loss of neutral wire in a split-phase grid	<ol style="list-style-type: none"> <li>1. The alarm clears automatically after grid power is restored.</li> <li>2. Check if the AC line or AC switch is disconnected.</li> </ol>

Fault Code	Fault Name	Fault Cause	Troubleshooting Suggestions
F160	EMS/Forced Off-grid	EMS issued a forced off-grid command, but the off-grid function is not enabled	Enable the off-grid function
F161	Passive Anti-islanding Protection	-	-
F162	Grid Type Fault	The actual grid type (two-phase or split-phase) does not match the set safety standard	Switch to the corresponding safety standard based on the actual grid type.
F12	30mA GFCI Protection	The input-to-ground insulation resistance becomes low during inverter operation.	<ol style="list-style-type: none"> <li>1. If it occurs occasionally, it may be caused by temporary external line abnormalities. The inverter will resume normal operation after the fault clears, requiring no manual intervention.</li> <li>2. If it occurs frequently or cannot be restored for a long time, please check if the PV string's ground impedance is too low.</li> </ol>

Fault Code	Fault Name	Fault Cause	Troubleshooting Suggestions
F13	60mA GFCI Protection	The input-to-ground insulation resistance becomes low during inverter operation.	<ol style="list-style-type: none"> <li>1. If it occurs occasionally, it may be caused by temporary external line abnormalities. The inverter will resume normal operation after the fault clears, requiring no manual intervention.</li> <li>2. If it occurs frequently or cannot be restored for a long time, please check if the PV string's ground impedance is too low.</li> </ol>
F14	150mA GFCI Protection	The input-to-ground insulation resistance becomes low during inverter operation.	<ol style="list-style-type: none"> <li>1. If it occurs occasionally, it may be caused by temporary external line abnormalities. The inverter will resume normal operation after the fault clears, requiring no manual intervention.</li> <li>2. If it occurs frequently or cannot be restored for a long time, please check if the PV string's ground impedance is too low.</li> </ol>
F15	GFCI Gradual Change Protection	The input-to-ground insulation resistance becomes low during inverter operation.	<ol style="list-style-type: none"> <li>1. If it occurs occasionally, it may be caused by temporary external line abnormalities. The inverter will resume normal operation after the fault clears, requiring no manual intervention.</li> <li>2. If it occurs frequently or cannot be restored for a long time, please check if the PV string's ground impedance is too low.</li> </ol>

Fault Code	Fault Name	Fault Cause	Troubleshooting Suggestions
F16	DCI Level 1 Protection	The DC component of the inverter output current exceeds the safety standard or the machine's default allowable range.	<ol style="list-style-type: none"> <li>1. If it's caused by an external fault, the inverter will automatically resume normal operation after the fault disappears, requiring no manual intervention.</li> <li>2. If this alarm occurs frequently and affects the normal power generation of the power station, please contact the dealer or after-sales service center.</li> </ol>
F17	DCI Level 2 Protection	The DC component of the inverter output current exceeds the safety standard or the machine's default allowable range.	<ol style="list-style-type: none"> <li>1. If it's caused by an external fault, the inverter will automatically resume normal operation after the fault disappears, requiring no manual intervention.</li> <li>2. If this alarm occurs frequently and affects the normal power generation of the power station, please contact the dealer or after-sales service center.</li> </ol>

Fault Code	Fault Name	Fault Cause	Troubleshooting Suggestions
F18	Low Insulation Resistance	<ol style="list-style-type: none"> <li>1. PV string shorted to protective earth (PE).</li> <li>2. The PV string is installed in a long-term humid environment with poor line-to-ground insulation.</li> <li>3. Low line-to-ground insulation resistance at the battery port.</li> </ol>	<ol style="list-style-type: none"> <li>1. Check the impedance of the PV string/battery port to protective earth. A value greater than 80kΩ is normal. If the measured value is less than 80kΩ, locate and rectify the short circuit point.</li> <li>2. Check if the inverter's protective earth wire is correctly connected.</li> <li>3. If the impedance is indeed below the default value in rainy/overcast environments, please reset the inverter's "Insulation Resistance Protection Point" via the App.</li> </ol> <p>For inverters in the Australian and New Zealand markets, insulation resistance faults can also be alerted in the following ways:</p> <ol style="list-style-type: none"> <li>1. The inverter is equipped with a buzzer. When a fault occurs, the buzzer sounds continuously for 1 minute; if the fault is not resolved, the buzzer sounds again every 30 minutes.</li> <li>2. If the inverter is added to a monitoring platform, after setting the alarm notification method, alarm information can be sent to customers via email.</li> </ol>

Fault Code	Fault Name	Fault Cause	Troubleshooting Suggestions
F19	Grounding Abnormal	<ol style="list-style-type: none"> <li>1. The inverter's protective earth wire is not connected.</li> <li>2. When the PV string output is grounded, the inverter output side is not connected to an isolation transformer.</li> </ol>	<ol style="list-style-type: none"> <li>1. Please confirm if the inverter's protective earth wire is properly connected.</li> <li>2. In scenarios where the PV string output is grounded, please confirm if an isolation transformer is connected to the inverter output side.</li> </ol>
F49	L-PE Short Circuit	Low impedance or short circuit between output phase line and PE	Measure the impedance between the output phase line and PE, locate and repair the point with abnormally low impedance.
F50	DCV Primary Protection	Abnormal Load Fluctuation	<ol style="list-style-type: none"> <li>1. If the abnormality is caused by an external fault, the inverter will automatically return to normal operation after the fault disappears, requiring no manual intervention.</li> <li>2. If this alarm occurs frequently and affects the normal power generation of the power station, please contact the dealer or after-sales service center.</li> </ol>

Fault Code	Fault Name	Fault Cause	Troubleshooting Suggestions
F51	DCV Secondary Protection	Abnormal Load Fluctuation	<p>1. If the abnormality is caused by an external fault, the inverter will automatically return to normal operation after the fault disappears, requiring no manual intervention.</p> <p>2. If this alarm occurs frequently and affects the normal power generation of the power station, please contact the dealer or after-sales service center.</p>
F20	Hardware Export Limit Protection	Abnormal Load Fluctuation	<p>1. If the abnormality is caused by an external fault, the inverter will automatically return to normal operation after the fault disappears, requiring no manual intervention.</p> <p>2. If this alarm occurs frequently and affects the normal power generation of the power station, please contact the dealer or after-sales service center.</p>
F21	Internal Comm Loss	Refer to specific subcode cause	<p>Turn off the AC output side switch and the DC input side switch. After 5 minutes, turn on the AC output side switch and the DC input side switch. If the fault persists, please contact the dealer or after-sales service center.</p>

Fault Code	Fault Name	Fault Cause	Troubleshooting Suggestions
F52	Residual Current (GFCI) Multiple Fault Shutdown	North American safety regulations require no automatic recovery after multiple faults; manual recovery or waiting 24h is required	1. Please check if the PV string's ground impedance is too low.
F53	DC Arc (AFCI) Multiple Fault Shutdown	North American safety regulations require no automatic recovery after multiple faults; manual recovery or waiting 24h is required	<ol style="list-style-type: none"> <li>1. After the unit reconnects to the grid, check if the voltage and current of each channel abnormally decrease or become zero;</li> <li>2. Check if the DC side terminals are securely connected.</li> </ol>

Fault Code	Fault Name	Fault Cause	Troubleshooting Suggestions
F54	External Communication Loss	Inverter external device communication lost, possibly due to peripheral device power supply issues, communication protocol mismatch, or lack of configuration for the corresponding peripheral device, etc.	Determine based on the actual model and detection enable bits; peripheral devices not supported by certain models will not be detected.
F55	Back-up Port Overload fault	1. Prevents the inverter from sustaining overload output.	1. Turn off some off-grid loads to reduce the inverter's off-grid output power.
F56	Back-up Port Overvoltage fault	2. Prevents inverter output overvoltage from damaging loads.	1. If it occurs occasionally, it may be caused by load switching and requires no manual intervention. 2. If it occurs frequently, please contact the dealer or after-sales service center.

Fault Code	Fault Name	Fault Cause	Troubleshooting Suggestions
F107	On-grid PWM Sync Failure	Abnormality occurred during carrier synchronization for grid connection	<ol style="list-style-type: none"> <li>1. Check if the synchronization cable connection is normal</li> <li>2. Check if the master/slave settings are normal;</li> <li>3. Turn off the AC output side switch and the DC input side switch. After 5 minutes, turn on the AC output side switch and the DC input side switch. If the fault persists, please contact the dealer or after-sales service center.</li> </ol>
F57	External Box fault	Waiting too long for the Box to switch relays during grid-to-off-grid transition	<ol style="list-style-type: none"> <li>1. Check if the Box is functioning normally;</li> <li>2. Check if the Box communication wiring is correct;</li> </ol>
-	Generator Failure	<ol style="list-style-type: none"> <li>1. This fault will be displayed continuously when no generator is connected</li> <li>2. When the generator is operating, this fault will be triggered if it does not meet generator safety regulations</li> </ol>	
F22	Generator Waveform Detection fault		
F23	Generator Abnormal Connection		
F24	Generator Voltage Low		
F25	Generator Voltage High		
F26	Generator Frequency Low		

Fault Code	Fault Name	Fault Cause	Troubleshooting Suggestions
F27	Generator Frequency High		<ol style="list-style-type: none"> <li>1. Ignore this fault when the generator is not connected;</li> <li>2. When this fault appears due to a generator failure, it is normal. After the generator recovers, wait for a period of time and the fault will clear automatically;</li> <li>3. This fault does not affect the normal operation of the off-grid mode;</li> <li>4. When both the generator and the grid are connected and safety regulations are met, the grid has priority for grid connection, and the system will operate in grid-connected mode.</li> </ol>
F109	External STS fault	Abnormal connection cable between inverter and STS	Check if the wiring sequence of the harness connecting the inverter and the STS corresponds one by one in order.
F58	CT Loss fault	CT connection wire disconnected (Japanese safety regulation requirement)	Check if the CT wiring is correct.

Fault Code	Fault Name	Fault Cause	Troubleshooting Suggestions
F110	Export Limit Protection	<ol style="list-style-type: none"> <li>1. Inverter reports error and disconnects from grid</li> <li>2. meter communication unstable</li> <li>3. Reverse power flow condition occurs</li> </ol>	<ol style="list-style-type: none"> <li>1. Check if the inverter has other error messages. If yes, perform targeted troubleshooting.</li> <li>2. Check if the connection to the meter is reliable</li> <li>3. If this alarm occurs frequently, affecting normal power generation of the power station, please contact the distributor or after-sales service center.</li> </ol>
F111	Bypass Overload	-	-
F112	Black Start Failure	-	-
F28	Parallel IO Self-check Abnormal	Parallel communication cable not securely connected or parallel IO chip damaged	Check if the parallel communication cable is securely connected, then check if the IO chip is damaged. If yes, replace the IO chip.
F59	Parallel CAN Communication Abnormal	Parallel communication cable not securely connected or some units are offline	Check if all units are powered on and if the parallel communication cables are securely connected.

<b>Fault Code</b>	<b>Fault Name</b>	<b>Fault Cause</b>	<b>Troubleshooting Suggestions</b>
F29	Paralell Grid Line Reversed	Grid lines of some units are reversed compared to others	Reconnect the grid lines.
F60	Parallel Back-up Line Reversed	Backup lines of some units are reversed compared to others	Reconnect the backup lines.
F61	Inverter Soft Start Failure	Inverter soft start failure during off-grid cold start	Check if the inverter module of the unit is damaged.
F113	Offgrid AC Ins Volt High	-	-
F30	AC HCT check Abnormal	AC sensor has sampling abnormality	Disconnect the AC output side switch and the DC input side switch, wait for 5 minutes, then close the AC output side switch and the DC input side switch. If the fault still exists, please contact the distributor or after-sales service center.
F62	AC HCT Failure	HCT sensor abnormality detected	Turn off the AC output side switch and the DC input side switch. After 5 minutes, turn on the AC output side switch and the DC input side switch. If the fault persists, please contact the dealer or after-sales service center.

Fault Code	Fault Name	Fault Cause	Troubleshooting Suggestions
F31	GFCI HCT Check Abnormal	GFCI sensor sampling abnormality detected	Turn off the AC output side switch and the DC input side switch. After 5 minutes, turn on the AC output side switch and the DC input side switch. If the fault persists, please contact the dealer or after-sales service center.
F63	GFCI HCT Failure	GFCI sensor abnormality detected	Turn off the AC output side switch and the DC input side switch. After 5 minutes, turn on the AC output side switch and the DC input side switch. If the fault persists, please contact the dealer or after-sales service center.
F32	Relay Check Abnormal	Relay abnormality, possible causes: 1. Relay fault (relay short circuit) 2. Relay sampling circuit abnormality. 3. AC side wiring abnormality (possible loose connection or short circuit)	Turn off the AC output side switch and the DC input side switch. After 5 minutes, turn on the AC output side switch and the DC input side switch. If the fault persists, please contact the dealer or after-sales service center.

Fault Code	Fault Name	Fault Cause	Troubleshooting Suggestions
F64	Relay Failure	<ol style="list-style-type: none"> <li>1. Relay fault (relay short circuit)</li> <li>2. Relay sampling circuit abnormality.</li> <li>3. AC side wiring abnormality (possible loose connection or short circuit)</li> </ol>	<p>Turn off the AC output side switch and the DC input side switch. After 5 minutes, turn on the AC output side switch and the DC input side switch. If the fault persists, please contact the dealer or after-sales service center.</p>
F164	DC Arcing Failure (String 17~32)	<ol style="list-style-type: none"> <li>1. Loose DC side connection terminals;</li> <li>2. Poor connection (loose) at DC side terminals;</li> <li>3. Damaged DC cable core causing poor connection</li> </ol>	<ol style="list-style-type: none"> <li>1. After the machine is reconnected to the grid, check if the voltage and current of each circuit abnormally decrease to zero;</li> <li>2. Check if the DC side terminals are securely connected.</li> </ol>

Fault Code	Fault Name	Fault Cause	Troubleshooting Suggestions
F165	DC Arcing Failure (String 33~48)	1. Loose DC side connection terminals; 2. Poor connection (loose) at DC side terminals; 3. Damaged DC cable core causing poor connection	1. After the machine is reconnected to the grid, check if the voltage and current of each circuit abnormally decrease to zero; 2. Check if the DC side terminals are securely connected.
F33	Flash Read/Write Error	Possible causes: Flash content changed; Flash end of life;	1. Upgrade to the latest program version. 2. Contact the dealer or after-sales service center.
F42	DC Arcing Failure (String 1~16)	1. Loose DC side connection terminals; 2. Poor connection (loose) at DC side terminals; 3. Damaged DC cable core causing poor connection	1. After the machine is reconnected to the grid, check if the voltage and current of each circuit abnormally decrease to zero; 2. Check if the DC side terminals are securely connected.

Fault Code	Fault Name	Fault Cause	Troubleshooting Suggestions
F34	AFCI Check Failure	The arc fault module did not detect an arc fault during the self-check process.	Turn off the AC output side switch and the DC input side switch. After 5 minutes, turn on the AC output side switch and the DC input side switch. If the fault persists, please contact the dealer or after-sales service center.
F65	AC Terminal Overtemperature	AC terminal overtemperature , possible causes: 1. Inverter installation location lacks ventilation. 2. Ambient temperature is too high. 3. Internal fan operation is abnormal.	1. Check if the ventilation at the inverter installation location is adequate and if the ambient temperature exceeds the maximum allowable range. 2. If ventilation is poor or ambient temperature is too high, improve its ventilation and heat dissipation conditions. 3. If ventilation and ambient temperature are both normal, please contact the dealer or after-sales service center.

Fault Code	Fault Name	Fault Cause	Troubleshooting Suggestions
F35	Cabinet Overtemperature	Cabinet overtemperature , possible causes: 1. Inverter installation location lacks ventilation. 2. Ambient temperature is too high. 3. Internal fan operation is abnormal.	
F66	INV Module Overtemperature	Inverter module overtemperature , possible causes: 1. Inverter installation location lacks ventilation. 2. Ambient temperature is too high. 3. Internal fan operation is abnormal.	

Fault Code	Fault Name	Fault Cause	Troubleshooting Suggestions
F67	Boost Module Overtemperature	Boost module overtemperature , possible causes: 1. Inverter installation location lacks ventilation. 2. Ambient temperature is too high. 3. Internal fan operation is abnormal.	
F68	AC Capacitor Overtemperature	Output filter capacitor overtemperature , possible causes: 1. Inverter installation location lacks ventilation. 2. Ambient temperature is too high. 3. Internal fan operation is abnormal.	

Fault Code	Fault Name	Fault Cause	Troubleshooting Suggestions
F114	Relay Failure2	Relay abnormality, possible causes: 1. Relay abnormality (relay short circuit) 2. Relay sampling circuit abnormality. 3. AC side wiring abnormality (possible poor connection or short circuit)	Turn off the AC output side switch and the DC input side switch, wait for 5 minutes, then turn on the AC output side switch and the DC input side switch. If the fault persists, please contact the distributor or after-sales service center.
F69	PV IGBT Short Circuit fault	Possible causes: 1. IGBT short circuit 2. Inverter sampling circuit abnormality	Turn off the AC output side switch and the DC input side switch, wait for 5 minutes, then turn on the AC output side switch and the DC input side switch. If the fault persists, please contact the distributor or after-sales service center.
F70	PV IGBT Open Circuit fault	1. Software issue causing no PWM output: 2. Drive circuit abnormality: 3. IGBT open circuit	Turn off the AC output side switch and the DC input side switch, wait for 5 minutes, then turn on the AC output side switch and the DC input side switch. If the fault persists, please contact the distributor or after-sales service center.

Fault Code	Fault Name	Fault Cause	Troubleshooting Suggestions
F71	NTC Abnormality	NTC temperature sensor abnormality	Turn off the AC output side switch and the DC input side switch, wait for 5 minutes, then turn on the AC output side switch and the DC input side switch. If the fault persists, please contact the distributor or after-sales service center.
F72	PWM Abnormal	PWM abnormal waveform detected	Turn off the AC output side switch and the DC input side switch, wait for 5 minutes, then turn on the AC output side switch and the DC input side switch. If the fault persists, please contact the distributor or after-sales service center.
F73	CPU Interrupt Abnormality	CPU interrupt abnormality	Turn off the AC output side switch and the DC input side switch, wait for 5 minutes, then turn on the AC output side switch and the DC input side switch. If the fault persists, please contact the distributor or after-sales service center.
F74	Microelectronics fault	Functional safety detected an abnormality	Turn off the AC output side switch and the DC input side switch, wait for 5 minutes, then turn on the AC output side switch and the DC input side switch. If the fault persists, please contact the distributor or after-sales service center.

<b>Fault Code</b>	<b>Fault Name</b>	<b>Fault Cause</b>	<b>Troubleshooting Suggestions</b>
F75	PV HCT fault	boost current sensor abnormality	Turn off the AC output side switch and the DC input side switch, wait for 5 minutes, then turn on the AC output side switch and the DC input side switch. If the fault persists, please contact the distributor or after-sales service center.
F76	1.5V Reference Abnormality	Reference circuit fault	Turn off the AC output side switch and the DC input side switch, wait for 5 minutes, then turn on the AC output side switch and the DC input side switch. If the fault persists, please contact the distributor or after-sales service center.
F77	0.3V Reference Abnormality	Reference circuit fault	
F78	CPLD Version Identification Error	CPLD version identification error	Turn off the AC output side switch and the DC input side switch, wait for 5 minutes, then turn on the AC output side switch and the DC input side switch. If the fault persists, please contact the distributor or after-sales service center.
F79	CPLD Communication fault	CPLD and DSP communication content error or timeout	Turn off the AC output side switch and the DC input side switch, wait for 5 minutes, then turn on the AC output side switch and the DC input side switch. If the fault persists, please contact the distributor or after-sales service center.

<b>Fault Code</b>	<b>Fault Name</b>	<b>Fault Cause</b>	<b>Troubleshooting Suggestions</b>
F80	Model Identification fault	Fault regarding model identification error	Turn off the AC output side switch and the DC input side switch, wait for 5 minutes, then turn on the AC output side switch and the DC input side switch. If the fault persists, please contact the distributor or after-sales service center.
F115	SVG Precharge Disabled	SVG precharge hardware failure	Contact the distributor or after-sales service center.
F116	Nighttime SVG PID Prevention fault	PID prevention hardware abnormality	Contact the distributor or after-sales service center.
F117	DSPVersion Identification Error	DSPSoftware Version Identification Error	Disconnect the AC output side switch and DC input side switch, 5 minutes after close the AC output side switch and DC input side switch, if the fault still exists, please contact the dealer or after-sales service center.
F36	Bus Overvoltage		Disconnect the AC output side switch and DC input side switch, 5 minutes after close the AC output side switch and DC input side switch, if the fault still exists, please contact the dealer or after-sales service center.
F81	P-Bus Overvoltage		
F82	N-Bus Overvoltage		
F83	Bus Overvoltage (subCPU1)		
F84	P-Bus Overvoltage (subCPU1)		

Fault Code	Fault Name	Fault Cause	Troubleshooting Suggestions
F85	N-Bus Overvoltage (subCPU1)	Bus Overvoltage, possible causes: 1. PV voltage is too high; 2. Inverter Bus voltage sampling is abnormal; 3. The isolation effect of the dual-split transformer at the inverter rear end is poor, causing mutual interference when two inverters are connected to the grid, and one inverter reports DC overvoltage when connected to the grid;	
F86	Bus Overvoltage (subCPU2)		
F87	P-Bus Overvoltage (subCPU2)		
F88	N-Bus Overvoltage (subCPU2)		
F89	P-Bus Overvoltage(CPLD)		
F90	N-Bus Overvoltage(CPLD)		

Fault Code	Fault Name	Fault Cause	Troubleshooting Suggestions
F118	MOSContinuous Overvoltage	1. Software issue causes the inverter drive to turn off earlier than the flyback drive; 2. Inverter drive circuit abnormality causes it to fail to turn on; 3. PV voltage is too high; 4. MOS voltage sampling is abnormal;	Disconnect the AC output side switch and DC input side switch, 5 minutes after close the AC output side switch and DC input side switch, if the fault still exists, please contact the dealer or after-sales service center.
F119	Bus Short Circuit Fault	1. Hardware damage	If a BUS short circuit fault occurs and the inverter remains off-grid, please contact the dealer or after-sales service center.
F120	Bus Sampling Abnormality	1. Bus voltage sampling hardware fault	Disconnect the AC output side switch and DC input side switch, 5 minutes after close the AC output side switch and DC input side switch, if the fault still exists, please contact the dealer or after-sales service center.

Fault Code	Fault Name	Fault Cause	Troubleshooting Suggestions
F121	DC Side Sampling Abnormal	1. Bus voltage sampling hardware fault 2. Battery voltage sampling hardware fault 3. Dcrlly relay fault	Turn off the AC output side switch and the DC input side switch, wait for 5 minutes, then turn on the AC output side switch and the DC input side switch. If the fault persists, please contact the distributor or after-sales service center.
F37	PV Input Overvoltage	PV input voltage is too high, possible causes: Incorrect photovoltaic array configuration, too many solar panels connected in series within a string, resulting in the string's open-circuit voltage exceeding the inverter's maximum working voltage.	Check the series configuration of the corresponding photovoltaic array string to ensure the string's open-circuit voltage does not exceed the inverter's maximum working voltage. After correcting the photovoltaic array configuration, the inverter alarm will automatically disappear.
F38	PV Sustained Hardware Overcurrent	1. Unreasonable module configuration 2. Hardware damage	

Fault Code	Fault Name	Fault Cause	Troubleshooting Suggestions
F39	PV Sustained Software Overcurrent	1. Unreasonable module configuration 2. Hardware damage	Turn off the AC output side switch and the DC input side switch, wait for 5 minutes, then turn on the AC output side switch and the DC input side switch. If the fault persists, please contact the distributor or after-sales service center.
F91	FlyCap Software Overvoltage	FlyCap overvoltage, possible causes: 1. PV voltage is too high; 2. Inverter FlyCap voltage sampling abnormal;	Turn off the AC output side switch and the DC input side switch, wait for 5 minutes, then turn on the AC output side switch and the DC input side switch. If the fault persists, please contact the distributor or after-sales service center.
F92	FlyCap Hardware Overvoltage	FlyCap overvoltage, possible causes: 1. PV voltage is too high; 2. Inverter FlyCap voltage sampling abnormal;	

Fault Code	Fault Name	Fault Cause	Troubleshooting Suggestions
F93	FlyCap Undervoltage	FlyCap undervoltage, possible causes: 1. Insufficient PV energy; 2. Inverter FlyCap voltage sampling abnormal;	
F94	FlyCap Precharge Failure	FlyCap precharge failure, possible causes: 1. Insufficient PV energy; 2. Inverter FlyCap voltage sampling abnormal;	
F95	FlyCap Precharge Abnormal	1. Unreasonable control loop parameters 2. Hardware damage	
F96	String Overcurrent (String 1~16)	Possible causes: 1. String overcurrent; 2. String current sensor abnormal	
F97	String Overcurrent (String 17~32)		

Fault Code	Fault Name	Fault Cause	Troubleshooting Suggestions
F40	String Reverse Connection (String 1~16)	PV string reverse connection	Check if the string is reversely connected.
F98	String Reverse Connection (String 17~32)	PV string reverse connection	Check if the string is reversely connected.
F99	String Loss (String 1~16)	String fuse disconnected (if present)	Check if the fuse is disconnected.
F100	String Loss (String 17~32)	String fuse disconnected (if present)	Check if the fuse is disconnected.

Fault Code	Fault Name	Fault Cause	Troubleshooting Suggestions
F122	PV Access Mode Setting Error	<p>PV Access Mode has three modes, taking a four-channel MPPT as an example:</p> <ol style="list-style-type: none"> <li>1. Parallel Mode: i.e., the AAAA mode (same-source mode), PV1-PV4 are from the same source, with the 4 PV channels connected to the same solar panel.</li> <li>2. Partial Parallel Mode: i.e., the AACC mode, PV1 and PV2 are connected from the same source, PV3 and PV4 are connected from the same source.</li> <li>3. Independent Mode: i.e., the ABCD mode (different-source), PV1, PV2, PV3, and</li> </ol>	<p>Check if the PV Access Mode is set correctly (ABCD, AACC, AAAA), and reset the PV Access Mode correctly.</p> <ol style="list-style-type: none"> <li>1. Confirm that each connected PV channel is correctly wired.</li> <li>2. If the PV is correctly connected, check via the App or screen whether the currently set "PV Access Mode" corresponds to the actual access mode.</li> <li>3. If the currently set "PV Access Mode" does not match the actual access mode, use the App or screen to set the "PV Access Mode" to the mode consistent with the actual situation. After setting, disconnect the PV and AC power supply and restart.</li> <li>4. After setting, if the current "PV Access Mode" matches the actual access mode but the fault persists, please contact the dealer or after-sales service center.</li> </ol>

Fault Code	Fault Name	Fault Cause	Troubleshooting Suggestions
		<p>PV4 are connected independently, with each of the 4 PV channels connected to one solar panel. This fault is reported if the actual PV access mode does not match the PV Access Mode set on the device.</p>	
-	String Reverse Connection (String 33~48)	PV String Reverse Connection	Check if the string is reversely connected.
-	String Missing (String 33~48)	String Fuse Open (if present)	Check if the fuse is open.

Fault Code	Fault Name	Fault Cause	Troubleshooting Suggestions
-	String Overcurrent (String 33~48)	Possible causes: 1. String overcurrent; 2. String current sensor abnormality	
F123	Multi-PV Channel Phase Error	PV Input Mode Setting Error	Check if the PV Access Mode is set correctly (ABCD, AACC, AAAA), and reset the PV Access Mode correctly 1. Confirm that each connected PV channel is correctly wired 2. If the PV is correctly connected, check via the App or screen whether the currently set "PV Access Mode" corresponds to the actual access mode 3. If the currently set "PV Access Mode" does not match the actual access mode, use the App or screen to set the "PV Access Mode" to the mode consistent with the actual situation. After setting, disconnect the PV and AC power supply and restart 4. After setting, if the current "PV Access Mode" matches the actual access mode but the fault persists, please contact the dealer or after-sales service center.

<b>Fault Code</b>	<b>Fault Name</b>	<b>Fault Cause</b>	<b>Troubleshooting Suggestions</b>
F101	Battery 1 Precharge Fault	Battery 1 precharge circuit fault (precharge resistor burnt, etc.)	Check if the precharge circuit is in good condition. After only the battery is powered on, check if the battery voltage matches the bus voltage. If not, please contact the dealer or after-sales service center.
F102	Battery 1 Relay Failure	Battery 1 relay cannot operate normally	After the battery is powered on, check if the battery relay is working and if a closing sound is heard. If it does not operate, please contact the dealer or after-sales service center.
F103	Battery 1 Connection Overvoltage	Battery 1 connection voltage exceeds the machine's rated range	Confirm if the battery voltage is within the machine's rated range.
F104	Battery 2 Precharge Fault	Battery 2 precharge circuit fault (precharge resistor burnt, etc.)	Check if the precharge circuit is in good condition. After only the battery is powered on, check if the battery voltage matches the bus voltage. If not, please contact the dealer or after-sales service center.
F105	Battery 2 Relay Failure	Battery 2 relay cannot operate normally	After the battery is powered on, check if the battery relay is working and if a closing sound is heard. If it does not operate, please contact the dealer or after-sales service center.

<b>Fault Code</b>	<b>Fault Name</b>	<b>Fault Cause</b>	<b>Troubleshooting Suggestions</b>
F106	Battery 2 Connection Overvoltage	Battery 2 connection voltage exceeds the machine's rated range	Confirm if the battery voltage is within the machine's rated range.
F124	Battery 1 Reverse Connection Fault	Battery 1 positive and negative terminals are reversed	Check if the polarities of the battery and the machine's terminals are consistent.
F125	Battery 2 Reverse Connection Fault	Battery 2 positive and negative terminals are reversed	Check if the polarities of the battery and the machine's terminals are consistent.
F126	Abnormal Battery Connection	Abnormal battery connection	Check if the battery is working normally.
-	BMS Status Bit Error	BMS Module Fault	Disconnect the AC output side switch and the DC input side switch, wait for 5 minutes, then close the AC output side switch and the DC input side switch. If the fault still exists, please contact the dealer or after-sales service center.
F127	BAT Overtemperature	Battery temperature is too high, possible causes: 1. Inverter installation location is not ventilated. 2. Ambient Overtemperature. 3. Internal fan operation is abnormal.	

<b>Fault Code</b>	<b>Fault Name</b>	<b>Fault Cause</b>	<b>Troubleshooting Suggestions</b>
F128	Ref Voltage Abnormal	Reference circuit fault	Turn off the AC output side switch and DC input side switch, close the AC output side switch and DC input side switch after 5 minutes. If the fault persists, please contact the dealer or after-sales service center.
F129	Cabinet Under Temperature	Cabinet temperature is too low, possible causes: 1. Ambient temperature is too low.	
F130	AC side SPD fault	AC side surge protective device failure	Replace the AC side surge protective device.
F131	DC side SPD fault	DC side surge protective device failure	Replace the DC side surge protective device.
F132	Internal fan abnormal	Internal fan abnormal, possible causes: 1. Fan power supply abnormal; 2. Mechanical fault (locked rotor); 3. Fan aging damage.	Turn off the AC output side switch and DC input side switch, close the AC output side switch and DC input side switch after 5 minutes. If the fault persists, please contact the dealer or after-sales service center.

Fault Code	Fault Name	Fault Cause	Troubleshooting Suggestions
F133	External Fan Abnormal	External fan abnormal, possible causes: 1. Fan power supply abnormal; 2. Mechanical fault (locked rotor); 3. Fan aging damage.	
F134	PID diagnosis abnormal	PID hardware fault or PV voltage too high causing PID pause	PID pause warning caused by high PV voltage requires no action. PID hardware fault can be cleared by turning the PID switch off and then on. Replace the PID device.
F135	Trip-Switch Trip Warning	Possible causes: Overcurrent or PV reverse connection caused the trip-switch to trip.	Please contact the dealer or after-sales service center. The tripping reason is PV short circuit or reverse connection. Check if there is a historical PV short circuit warning or historical PV reverse connection warning. If present, maintenance personnel need to check the corresponding PV condition. After checking and confirming no fault, you can manually close the trip-switch and clear this warning via the App interface's clear historical fault operation.

Fault Code	Fault Name	Fault Cause	Troubleshooting Suggestions
F13 6	Historical PV IGBT short circuit warning	Possible causes: Overcurrent caused the trip-switch to trip.	Please contact the dealer or after-sales service center. Maintenance personnel need to check the Boost hardware and external string for faults according to the historical PV short circuit warning subcode. After checking and confirming no fault, this warning can be cleared via the App interface's clear historical fault operation.
F13 7	Historical PV reverse connection warning (String 1~16)	Possible causes: PV reverse connection caused the trip-switch to trip.	Contact the dealer or after-sales service center. Maintenance personnel need to check the corresponding string for reverse connection and check if there is a voltage difference in the PV panel configuration according to the historical PV reverse connection warning subcode. After checking and confirming no fault, this warning can be cleared via the App interface's clear historical fault operation.

Fault Code	Fault Name	Fault Cause	Troubleshooting Suggestions
F138	Historical PV reverse connection warning (String 17~32)	Possible causes: PV reverse connection caused the trip-switch to trip.	Contact the dealer or after-sales service center. Maintenance personnel need to check the corresponding string for reverse connection and check if there is a voltage difference in the PV panel configuration according to the historical PV reverse connection warning subcode. After checking and confirming no fault, this warning can be cleared via the App interface's clear historical fault operation.
F139	Flash read/write error warning	Possible causes: flash content changed; flash lifespan exhausted;	<ol style="list-style-type: none"> <li>1. Upgrade to the latest firmware.</li> <li>2. Contact the dealer or after-sales service center.</li> </ol>

Fault Code	Fault Name	Fault Cause	Troubleshooting Suggestions
F140	Meter Comm Loss	<p>This warning may only occur after anti-backfeed function is enabled. Possible causes:</p> <ol style="list-style-type: none"> <li>1. Meter not connected;</li> <li>2. Communication cable connection between meter and inverter is incorrect.</li> </ol>	<p>Check the meter wiring, connect the meter correctly. If the fault persists after checking, please contact the dealer or after-sales service center.</p>
F141	PV panel type identification failure	PV panel identification hardware abnormal	<p>Contact the dealer or after-sales service center.</p>
F142	PV String Mismatch	<p>PV string mismatch, the open-circuit voltage configurations differ between the two strings under the same MPPT circuit.</p>	<p>Check the open-circuit voltage of the two strings. Configure strings with the same open-circuit voltage under the same MPPT circuit. Prolonged string mismatch poses a safety hazard.</p>
F143	CT Not Connected	CT not connected	<p>Check the CT wiring.</p>
F144	CT Reversed Connection	CT reversed connection	<p>Check the CT wiring.</p>

<b>Fault Code</b>	<b>Fault Name</b>	<b>Fault Cause</b>	<b>Troubleshooting Suggestions</b>
F145	PE Loss	Protective earth (PE) wire not connected	Check the protective earth (PE) wire.
F146	High PV String Terminal Temperature (String 1~8)	Register 37176 PV terminal temperature alarm subcode 1 is set.	-
F147	High PV String Terminal Temperature (String 9~16)	Register 37177 PV terminal temperature alarm subcode 2 is set.	-
F148	High PV String Terminal Temperature (String 17~20)	Register 37178 PV terminal temperature alarm subcode 3 is set.	-
F149	Historical PV Reverse Connection Warning (String 33~48)	Possible causes: PV reverse connection caused the disconnect switch to trip.	Please contact the dealer or after-sales service center. The maintenance personnel should check the corresponding string for reverse connection based on the historical PV reverse connection warning subcode, and check if there is a voltage difference in the PV panel configuration. If no fault is found after inspection, this warning can be cleared by performing the clear historical fault operation in the App interface.

<b>Fault Code</b>	<b>Fault Name</b>	<b>Fault Cause</b>	<b>Troubleshooting Suggestions</b>
F150	Battery 1 Voltage Low	Battery voltage is below the set value.	-
F151	Battery 2 Voltage Low	Battery voltage is below the set value.	-
F152	Low Voltage of Battery Power	Battery is not in charging mode, and voltage is below the shutdown voltage.	-
F153	BAT1 Voltage High	-	-
F154	Battery 2 Voltage High	-	-
F155	Online Low Insulation Resistance	<p>1. PV string is short-circuited to protective earth.</p> <p>2. The PV string is installed in a long-term humid environment with poor line-to-earth insulation.</p>	<p>1. Check the impedance between the PV string and protective earth. If a short circuit is found, rectify the short circuit point.</p> <p>2. Check if the inverter's protective earth wire is correctly connected.</p> <p>3. If it is confirmed that the impedance is indeed below the default value in rainy/overcast conditions, please reconfigure the "Insulation Resistance Protection Point".</p>

<b>Fault Code</b>	<b>Fault Name</b>	<b>Fault Cause</b>	<b>Troubleshooting Suggestions</b>
F156	Micro-grid Overload Warning	Excessive input current on the backup side.	Occasional occurrence requires no action; if this alarm appears frequently, please contact the dealer or after-sales service center.
F157	Manual Reset	-	-
F158	Generator Phase Sequence Abnormal	-	-
F159	Multiplexed Port Configuration Abnormal	The multiplexed (generator) port is configured for microgrid or large load, but a generator is actually connected.	Use the App to change the configuration of the multiplexed (generator) port.

Fault Code	Fault Name	Fault Cause	Troubleshooting Suggestions
F41	Generator Port Overload	<ol style="list-style-type: none"> <li>1. Off-grid side output exceeds the requirements specified in the specification.</li> <li>2. Short circuit on the off-grid side.</li> <li>3. Off-grid terminal voltage is too low.</li> <li>4. When used as a large load port, the large load exceeds the requirements specified in the specification.</li> </ol>	<p>Confirm the cause of the issue by checking data such as off-grid side output voltage, current, and power through the data.</p>
F108	DSP Communication Failure	-	-

<b>Fault Name</b>	<b>Fault Cause</b>	<b>Troubleshooting Recommendation</b>
Parallel Comm Timeout Shutdown	In parallel configuration, if the slave unit has not communicated with the master for over 400 seconds	Check if the parallel communication harness is securely connected. Check if slave addresses are duplicated.
One-Key Shutdown	Check via the App if the one-key shutdown function is enabled	Disable the one-key shutdown.
Offline Shutdown	-	-
Remote Shutdown	-	-
Child Node Communication Failure	Internal Comm Abnormal	Restart the unit and observe if the fault clears.
DG Communication Failure	Abnormal communication link between the control board and the diesel generator	<ol style="list-style-type: none"> <li>1. Check the communication harness for the link and observe if the fault clears;</li> <li>2. Try restarting the unit and observe if the fault clears;</li> <li>3. If the fault persists after restart, contact the after-sales service center.</li> </ol>
Battery Over Voltage	1. Individual cell voltage too high 2. Voltage sensing line abnormal	
	1. Total battery voltage too high 2. Voltage sensing line abnormal	
Battery Undervoltage	1. Individual cell voltage too low 2. Voltage sensing line abnormal	

Fault Name	Fault Cause	Troubleshooting Recommendation
	<ol style="list-style-type: none"> <li>1. Total battery voltage too low</li> <li>2. Voltage sensing line abnormal</li> </ol>	<p>Record the fault phenomenon, restart the battery, wait a few minutes, confirm if the fault disappears. If the problem persists after restart, please contact the after-sales service center.</p>
Battery Overcurrent	<ol style="list-style-type: none"> <li>1. Charging current too high, battery current limiting abnormal: sudden change in temperature and voltage values</li> <li>2. Inverter response abnormal</li> </ol>	
	Battery discharge current too high	
Battery Overtemperature	<ol style="list-style-type: none"> <li>1. Ambient Overtemperature</li> <li>2. Temperature sensor abnormal</li> </ol>	
	<ol style="list-style-type: none"> <li>1. Ambient Overtemperature</li> <li>2. Temperature sensor abnormal</li> </ol>	
Battery Undertemperature	<ol style="list-style-type: none"> <li>1. Ambient temperature too low</li> <li>2. Temperature sensor abnormal</li> </ol>	
	<ol style="list-style-type: none"> <li>1. Ambient temperature too low</li> <li>2. Temperature sensor abnormal</li> </ol>	
Battery Terminal Overtemperature	Terminal temperature too high	

Fault Name	Fault Cause	Troubleshooting Recommendation
Battery Imbalance	<p>1. Excessive temperature difference. At different stages, the battery will limit battery power, i.e., limit charge/discharge current. Therefore, this issue is generally difficult to occur.</p> <p>2. Cell capacity degradation leads to excessive internal resistance, causing large temperature rise during overcurrent, resulting in significant temperature difference.</p> <p>3. Poor welding of cell tabs leads to rapid cell temperature rise during overcurrent.</p> <p>4. Temperature sampling issue;</p> <p>5. Power line connection loose</p> <hr/> <p>1. Inconsistent cell aging</p> <p>2. Slave board chip issues can also cause excessive cell voltage difference;</p> <p>3. Slave board balancing issues can also cause excessive cell voltage difference</p> <p>4. Harness issues</p> <hr/> <p>1. Inconsistent cell aging</p> <p>2. Slave board chip issues can also cause excessive cell voltage difference;</p> <p>3. Slave board balancing issues can also cause excessive cell voltage difference</p> <p>4. Harness issues</p>	
Insulation Resistance	Insulation resistance damaged	Check if the ground wire is properly connected, restart the battery. If the problem persists after restart, please contact the after-sales service center.

Fault Name	Fault Cause	Troubleshooting Recommendation
Pre-charging Failure	Pre-charging failure	Indicates that during the pre-charging process, the voltage across the pre-charge MOS always exceeds the specified threshold. After shutdown and restart, observe if this fault persists. Check if the wiring is correct and if the pre-charge MOS is damaged.
Sensing Line Fault	Battery sensing line poor contact or disconnected	Check wiring, restart the battery. If the problem persists after restart, please contact the after-sales service center.
	Cell voltage sensing line poor contact or disconnected	Check wiring, restart the battery. If the problem persists after restart, please contact the after-sales service center.
	Cell temperature sensing line poor contact or disconnected	
	Excessive error in dual-channel current comparison, or abnormal current sensing line circuit	
	Excessive error in dual-channel voltage comparison or MCU vs AFE voltage comparison, or abnormal voltage sensing line circuit	
	Temperature sensing line circuit abnormal or poor contact/disconnected	

Fault Name	Fault Cause	Troubleshooting Recommendation
	Overvoltage level 5 or overtemperature level 5, tripping the three-terminal fuse	Tripped three-terminal fuse requires contacting the after-sales service center to replace the main control board.
Relay or MOS Overtemperature	Relay or MOS overtemperature	This fault indicates the MOS transistor temperature exceeds the specified threshold. Shut down and let it sit for 2h for temperature recovery.
Shunt Overtemperature	Shunt overtemperature	This fault indicates the shunt transistor temperature exceeds the specified threshold. Shut down and let it sit for 2h for temperature recovery.
BMS1 Other Faults 1 (Residential Storage)	Relay or MOS open circuit	<ol style="list-style-type: none"> <li>1. Upgrade software, shut down and let it sit for 5 minutes, restart and see if the fault persists;</li> <li>2. If it persists, replace the battery pack.</li> </ol>

Fault Name	Fault Cause	Troubleshooting Recommendation
	Relay or MOS short circuit	<ol style="list-style-type: none"> <li>1. Upgrade software, shut down and let it sit for 5 minutes, restart and see if the fault persists;</li> <li>2. If it persists, replace the battery pack.</li> </ol>
	Communication abnormal between main cluster and slave cluster, or cell inconsistency between clusters	<ol style="list-style-type: none"> <li>1. Check the battery information and software version of the slave unit, and whether the communication cable connection to the master unit is normal.</li> <li>2. Upgrade software.</li> </ol>
	Battery system loop harness abnormal, causing interlock signal not forming a loop	Check if the terminal resistor is installed correctly.
	BMS and PCS communication abnormal	<ol style="list-style-type: none"> <li>1. Confirm if the communication cable interface definition between the inverter and the connected battery is correct;</li> <li>2. Please contact the after-sales service center to check backend data and observe if the inverter and battery software match correctly.</li> </ol>

Fault Name	Fault Cause	Troubleshooting Recommendation
	BMS master and slave control communication harness abnormal	1. Check wiring, restart the battery;
	Communication loss between main negative chips	2. Upgrade the battery. If the problem persists after restart, please contact the after-sales service center.
	Circuit breaker, shunt trip abnormal	1. Shut down and let it sit for 5 minutes, restart and see if the fault persists; 2. Observe the blind plugs at the bottom of PACK and PCU, check if communication pins are loose or bent;
	MCU self-test failure	Upgrade software, restart the battery. If the problem persists after restart, please contact the after-sales service center.
	1. Software version too low or BMS board damaged 2. High number of parallel inverters, causing excessive inrush current during battery pre-charge	1. Upgrade software, observe if the fault persists. 2. In case of parallel configuration, black-start the battery first, then start the inverters.

Fault Name	Fault Cause	Troubleshooting Recommendation
	MCU internal fault	Upgrade software, restart the battery. Usually indicates MCU or external component damage. If the problem persists after restart, please contact the after-sales service center.
	Main control current greater than specified threshold	<ol style="list-style-type: none"> <li>1. Shut down and let it sit for 5 minutes, restart and see if the fault persists;</li> <li>2. Check if the inverter power setting is too high, causing it to exceed the bus load;</li> </ol>
	Inconsistent cells in parallel clusters	Confirm if the cells in the parallel battery clusters are consistent.
	Reverse polarity connection of parallel cluster battery positive and negative terminals	Check if the positive and negative terminals of the parallel cluster batteries are reversed.
	Severe overtemperature, overvoltage, etc., triggering the fire protection system	Contact the after-sales service center.
Air Conditioner Failure	Air conditioner abnormal failure	Try restarting the system. If the fault is not resolved, please contact the after-sales service center.

Fault Name	Fault Cause	Troubleshooting Recommendation
	Cabinet door not closed	Check if the cabinet door is properly closed.
	Supply voltage too high	Confirm if the supply voltage value meets the air conditioner input voltage requirements. Re-power after confirmation.
	Insufficient supply voltage	
	No voltage input	
	Unstable supply voltage	
	Compressor voltage unstable	Try restarting the system. If the fault is not resolved, please contact the after-sales service center.
	Sensor poor contact or damaged	
	Air conditioner fan abnormal	
BMS1 Other Faults 2 (Residential Storage)	Internal voltage or current abnormal in DCDC	Refer to specific DC fault content.
	DCDC overload or heatsink temperature too high, etc.	
	Cell sensing abnormal or inconsistent aging	Please contact the after-sales service center.
	Fan action not executed normally	Please contact the after-sales service center.
	Output port screws loose or poor contact	<ol style="list-style-type: none"> <li>1. Shut down the battery, check wiring and output port screw condition.</li> <li>2. After confirmation, restart the battery, observe if the fault persists. If it exists, please contact the after-sales service center.</li> </ol>

Fault Name	Fault Cause	Troubleshooting Recommendation
	Battery used for too long or cells severely damaged	Please contact the after-sales service center to replace the pack.
	1. Software version too low or BMS board damaged 2. High number of parallel inverters, causing excessive inrush current during battery pre-charge	1. Upgrade software, observe if the fault persists. 2. In case of parallel configuration, black-start the battery first, then start the inverters.
	Heating film damaged	Please contact the after-sales service center.
	Heating film three-terminal fuse blown, heating function unavailable	Please contact the after-sales service center.
	Software model, Cell Type, hardware model mismatch	Check if the software model, SN, Cell Type, and hardware model are consistent. If not, please contact the after-sales service center.
	Thermal management board communication line break	1. Shut down and let it sit for 5 minutes, restart and see if the fault persists; 2. If the fault does not recover, contact after-sales to replace the pack.

Fault Name	Fault Cause	Troubleshooting Recommendation
	Thermal management board communication line break	<ol style="list-style-type: none"> <li>1. Shut down and let it sit for 5 minutes, restart and see if the fault persists;</li> <li>2. If the fault does not recover, contact after-sales to replace the pack.</li> </ol>
	Thermal management board communication line break	<ol style="list-style-type: none"> <li>1. Shut down and let it sit for 5 minutes, restart and see if the fault persists;</li> <li>2. If the fault does not recover, contact after-sales to replace the pack.</li> </ol>
	Pack fan fault signal triggered	<ol style="list-style-type: none"> <li>1. Shut down and let it sit for 5 minutes, restart and see if the fault persists;</li> <li>2. If the fault does not recover, contact after-sales to replace the pack.</li> </ol>
DCDC Fault	Output port voltage too high	Check output port voltage. If the output port voltage is normal and the fault does not clear itself after restarting the battery, please contact the after-sales service center.

Fault Name	Fault Cause	Troubleshooting Recommendation
	DCDC module detects battery voltage exceeding maximum charging voltage	Stop charging, discharge to below 90% SOC or let it sit for 2h. If ineffective and the fault persists after restart, please contact the after-sales service center.
	Heatsink temperature too high	Let the battery sit for 1h for heatsink temperature to drop. If ineffective and the fault persists after restart, please contact the after-sales service center.
	Battery discharge current too high	Check if the load exceeds the battery's discharge capability. Turn off the load or stop PCS operation for 60s. If ineffective and the fault persists after restart, please contact the after-sales service center.
	Output port power harness positive/negative reversed with parallel cluster battery or PCS	Turn off the battery manual switch, check if the output port wiring is correct, restart the battery.

Fault Name	Fault Cause	Troubleshooting Recommendation
	Output power relay cannot close	Check if the output port wiring is correct, if there is a short circuit. If ineffective and the fault persists after restart, please contact the after-sales service center.
	Power device temperature too high	Let the battery sit for 1h for internal power device temperature to drop. If ineffective and the fault persists after restart, please contact the after-sales service center.
	Relay welded/sticking	If the fault persists after restart, please contact the after-sales service center.
Battery Rack Circulating Current Failure	<ol style="list-style-type: none"> <li>1. Cell imbalance</li> <li>2. First power-up without full charge calibration</li> </ol>	-
BMS1 Other Faults 3 (Large-scale Storage)	Communication abnormal with linux module	<ol style="list-style-type: none"> <li>1. Check if the communication cable link is normal.</li> <li>2. Upgrade software, restart the battery and observe if the fault persists. If it exists, please contact the after-sales service center.</li> </ol>

Fault Name	Fault Cause	Troubleshooting Recommendation
	Cell temperature rise too fast	Cell abnormal, contact after-sales to replace the pack.
	SOC below 10%	Charge the battery.
	SN writing does not conform to rules	Check if the SN digit count is normal. If abnormal, please contact the after-sales service center.
	<ol style="list-style-type: none"> <li>1. Daisy chain communication abnormal within battery cluster</li> <li>2. Inconsistent cell aging between battery clusters</li> </ol>	<ol style="list-style-type: none"> <li>1. Check the contact condition of packs within a single cluster.</li> <li>2. Confirm the usage of each cluster battery, such as cumulative charge/discharge capacity, cycle count, etc.</li> <li>3. Please contact the after-sales service center.</li> </ol>
	Excessive humidity inside pack	-
	Fuse blown	Contact after-sales to replace the pack.
	Battery low charge	Charge the battery.
BMS1 Other Faults 4 (Large-scale Storage)	Circuit breaker abnormal	Contact after-sales to replace the pack.
	External device abnormal	Contact after-sales to replace the pack.

Fault Name	Fault Cause	Troubleshooting Recommendation
Contactors Failure 1	-	-
Contactors Failure 2	-	-
Overload Protection (Ksic)	Continuous overload (exceeding 690KVA) for 10s	Please contact the after-sales service center.
Overload Protection (Smart Port)	Continuous overload (exceeding 690KVA) for 10s	Please contact the after-sales service center.
Master AC On Meter Comm Error	<ol style="list-style-type: none"> <li>1. Possibly the meter is not connected to the master</li> <li>2. Possibly the meter communication cable is loose</li> </ol>	<ol style="list-style-type: none"> <li>1. Check if the meter is connected to the master.</li> <li>2. Check if the meter communication cable is loose.</li> </ol>
Parallel Slave Meter Error	Meter connected to slave unit	Set the machine with the meter connected as the master.
Slave AC On Timeout with Master	<ol style="list-style-type: none"> <li>1. Slave address setting error</li> <li>2. Slave communication cable loose</li> </ol>	<ol style="list-style-type: none"> <li>1. Check if slave addresses are duplicated.</li> <li>2. Check if the parallel communication cable is loose.</li> </ol>

## 9.5 Routine Maintenance



- Ensure the inverter is powered off.
- Wear personal protective equipment when operating the inverter.

Maintenance Item	Maintenance Method	Maintenance Cycle
System Cleaning	Check if there is any foreign object or dust on the heat sink and air inlet/outlet.	Once every 6 months to once a year
DC Switch	Turn the DC switch on and off 10 times consecutively to ensure its proper function.	Once a year
Electrical Connections	Check if electrical connections are loose, if cable appearance is damaged, or if copper exposure occurs.	Once every 6 months to once a year
Sealing	Check if the sealing of the equipment's cable entry holes meets requirements. If gaps are too large or unsealed, reseal them.	Once a year
THDi Test	According to Australian requirements, add Zref between the inverter and the grid during the THDi test. L:0.24 $\Omega$ + j0.15 $\Omega$ ; N:0.16 $\Omega$ +j0.10 $\Omega$ L:0.15 $\Omega$ + j0.15 $\Omega$ ; N:0.1 $\Omega$ + j0.1 $\Omega$	As required.

# 10 technical parameter

## 10.1 Technical Parameters

Technical Data	GW3600N-EH	GW5000N-EH	GW5000N-EH-BE	GW6000N-EH
Battery Input Data				
Battery Type	Li-Ion	Li-Ion	Li-Ion	Li-Ion
Nominal Battery Voltage (V)	350	350	350	350
Battery Voltage Range (V)	85~460	85~460	85~460	85~460
Start-up Voltage (V)	85	85	85	85
Number of Battery Input	1	1	1	1
Max. Continuous Charging Current (A)	25	25	25	25
Max. Continuous Discharging Current (A)	25	25	25	25
Max. Charge Power (W)	6000	6000	6000	6000
Max. Discharge Power (W)	3600	5000	5000	6000
PV String Input Data				
Max. Input Power (W)*1	5400	7500	7500	9000

<b>Technical Data</b>	<b>GW3600N-EH</b>	<b>GW5000N-EH</b>	<b>GW5000N-EH-BE</b>	<b>GW6000N-EH</b>
Max. Input Voltage (V)	580	580	580	580
MPPT Operating Voltage Range (V)	100~550	100~550	100~550	100~550
MPPT Voltage Range at Nominal Power	150~550	210~550	210~550	250~550
Start-up Voltage (V)	85	85	85	85
Nominal Input Voltage (V)	380	380	380	380
Max. Input Current per MPPT (A)	16	16	16	16
Max. Short Circuit Current per MPPT (A)	21.2	21.2	21.2	21.2
Max. Backfeed Current to The Array (A)	0	0	0	0
Number of MPP Trackers	2	2	2	2
Number of Strings per MPPT	1	1	1	1
<b>AC Output Data (On-grid)</b>				
Nominal Output Power (W)	3600	5000	5000	6000

<b>Technical Data</b>	<b>GW3600N-EH</b>	<b>GW5000N-EH</b>	<b>GW5000N-EH-BE</b>	<b>GW6000N-EH</b>
Max. Output Power (W)	3600/3960*2	5000/5500*2	5000	6000/6600*2
Nominal Apparent Power Output to Utility Grid (VA)*3	3600	5000	5000	6000
Max. Apparent Power Output to Utility Grid (VA)*3	3600/3960*2	5000/5500*2	5000	6000/6600*2
Nominal Apparent Power from Utility Grid (VA)	7200	10000	10000	12000
Max. Apparent Power from Utility Grid (VA)	7200 (Charging 3.6kW, Backup Output 3.6kW)	10000 (Charging 5kW, Backup Output 5kW)	10,000 (Charging 5kW, Backup Output 5kW)	12000 (Charging 6kW, Backup Output 6kW)
Nominal Output Voltage (V)	230/220*7	230/220*7	230	230/220*7
Output Voltage Range (V)	0~300	0~300	0~300	0~300
Nominal AC Grid Frequency (Hz)	50/60	50/60	50/60	50/60
AC Grid Frequency Range (Hz)	45~65	45~65	45~65	45~65

Technical Data	GW3600N-EH	GW5000N-EH	GW5000N-EH-BE	GW6000N-EH
Max. AC Current Output to Utility Grid (A)	16/18* <sup>2</sup>	21.7/24* <sup>2</sup>	21.7	26.1/28.7* <sup>2</sup> /27.3* <sup>8</sup>
Max. AC Current From Utility Grid (A)	32	43.4	43.4	52.2
Nominal AC Current From Utility Grid (A)	32	43.4	43.4	52.2
Max. Output Fault Current (Peak and Duration) (A)	65A@5us	65A@5us	65A@5us	65A@5us
Inrush Current (Peak and Duration) (A)	65A@5us	65A@5us	65A@5us	65A@5us
Nominal Output Current (A)	15.6	21.7	21.7	26.1
Power Factor	~1 (Adjustable from 0.8 leading to 0.8lagging)			
Max. Total Harmonic Distortion	<3%	<3%	<3%	<3%
Maximum Output Overcurrent Protection (A)	17.2	23.9	23.9	28.7
Type of Voltage (a.c. or d.c.)	a.c.	a.c.	a.c.	a.c.
AC Output Data (Back-up)				

Technical Data	GW3600N-EH	GW5000N-EH	GW5000N-EH-BE	GW6000N-EH
Back-up Nominal Apparent Power (VA)	3600	5000	5000	6000
Max. Output Apparent Power without Grid(VA)	3600 (4320@60sec)	5000 (6000@60sec)	5000 (6000@60sec)	6000 (7200@60sec)
Max. Output Apparent Power with Grid(VA)	3600	5000	5000	6000
Nominal Output Current (A)	15.7	21.7	21.7	26.1
Max. Output Current (A)	15.7	21.7	21.7	26.1
Max. Output Fault Current (Peak and Duration) (A)	65A@5us	65A@5us	65A@5us	65A@5us
Inrush Current (Peak and Duration) (A)	65A@5us	65A@5us	65A@5us	65A@5us
Maximum Output Overcurrent Protection (A)	18.8	26.1	26.1	31.3
Nominal Output Voltage (V)	230(±2%)	230(±2%)	230(±2%)	65A@5us
Nominal Output Frequency (Hz)	50/60(+0.2%)	50/60(+0.2%)	50/60(+0.2%)	65A@5us

<b>Technical Data</b>	<b>GW3600N-EH</b>	<b>GW5000N-EH</b>	<b>GW5000N-EH-BE</b>	<b>GW6000N-EH</b>
Output THDv (@Linear Load)	<3%	<3%	<3%	65A@5us
Efficiency				
Max. Efficiency	97.6%	97.6%	97.6%	97.6%
European Efficiency	97.0%	97.0%	97.0%	97.0%
Max. Battery to AC Efficiency	96.6%	96.6%	96.6%	96.6%
MPPT Efficiency Protection	99.9%	99.9%	99.9%	99.9%
Protection				
PV String Current Monitoring	Integrated	Integrated	Integrated	Integrated
PV Insulation Resistance Detection	Integrated	Integrated	Integrated	Integrated
Residual Current Monitoring	Integrated	Integrated	Integrated	Integrated
PV Reverse Polarity Protection	Integrated	Integrated	Integrated	Integrated
Battery Reverse Polarity Protection	Integrated	Integrated	Integrated	Integrated
Anti-islanding Protection	Integrated	Integrated	Integrated	Integrated
AC Overcurrent Protection	Integrated	Integrated	Integrated	Integrated

<b>Technical Data</b>	<b>GW3600N-EH</b>	<b>GW5000N-EH</b>	<b>GW5000N-EH-BE</b>	<b>GW6000N-EH</b>
AC Short Circuit Protection	Integrated	Integrated	Integrated	Integrated
AC Overvoltage Protection	Integrated	Integrated	Integrated	Integrated
DC Switch	Integrated	Integrated	Integrated	Integrated
DC Surge Protection	Type II	Type II	Type II	Type II
AC Surge protection	Type III	Type III	Type III	Type III
Remote Shutdown	Integrated	Integrated	Integrated	Integrated
<b>General Data</b>				
Operating Temperature Range (°C)	-25~+60	-25~+60	-25~+60	-25~+60
Relative Humidity	0~95%	0~95%	0~95%	0~95%
Max. Operating Altitude (m)	3000*10	3000*10	3000*10	3000*10
Cooling Method	Natural Convection	Natural Convection	Natural Convection	Natural Convection
User Interface	LED, APP	LED, APP	LED, APP	LED, APP
Communication with BMS*4	RS485, CAN	RS485, CAN	RS485, CAN	RS485, CAN
Communication with Meter	RS485	RS485	RS485	RS485

Technical Data	GW3600N-EH	GW5000N-EH	GW5000N-EH-BE	GW6000N-EH
Communication with Portal	WiFi / Ethernet (Optional)	WiFi / Ethernet (Optional)	WiFi / Ethernet (Optional)	WiFi / Ethernet (Optional)
Weight (kg)	17	17	17	17
Dimension (WxHxD mm)	354x433x147	354x433x147	354x433x147	354x433x147
Noise Emission (dB)	<35	<35	<35	<35
Topology	Non-isolated	Non-isolated	Non-isolated	Non-isolated
Self-consumption at Night (W) <sup>*5</sup>	<10	<10	<10	<10
Ingress Protection Rating	IP65	IP65	IP65	IP65
DC Connector	MC4 (4~6 mm <sup>2</sup> )	MC4 (4~6 mm <sup>2</sup> )	MC4 (4~6 mm <sup>2</sup> )	MC4 (4~6 mm <sup>2</sup> )
AC Connector	Quick Plug	Quick Plug	Quick Plug	Quick Plug
Environmental Category	4K4H	4K4H	4K4H	4K4H
Pollution Degree	III	III	III	III
Overvoltage Category	DC II / AC III	DC II / AC III	DC II / AC III	DC II / AC III
Protective Class	I	I	I	I
Storage Temperature (°C)	-40~+85	-40~+85	-40~+85	-40~+85

Technical Data	GW3600N-EH	GW5000N-EH	GW5000N-EH-BE	GW6000N-EH
The Decisive Voltage Class (DVC)	Battery: C PV: C AC: C Com: A	Battery: C PV: C AC: C Com: A	Battery: C PV: C AC: C Com: A	Battery: C PV: C AC: C Com: A
Mounting Method	Wall Mounted	Wall Mounted	Wall Mounted	Wall Mounted
Active Anti-islanding Method	AFDPF+ AQDPF* <sup>9</sup>	AFDPF+ AQDPF* <sup>9</sup>	AFDPF+ AQDPF* <sup>9</sup>	AFDPF+ AQDPF* <sup>9</sup>
Type of Electrical Supply System	Single phase TN/TT system	Single phase TN/TT system	Single phase TN/TT system	Single phase TN/TT system
Country of Manufacture	China	China	China	China
Certification* <sup>6</sup>				
Grid Standards	VDE-AR-N 4105, G98, G100, CEI 0-21,AS/NZS477.2, NRS097-2-1			
Safety Regulation	IEC/EN 62109-1&2			
EMC	EN61000-6-1, EN61000-6-2, EN61000-6-3, EN61000-6-4,EN 61000-4-16,EN 61000-4-18, EN 61000-4-29			

\*1: In Australia, for most PV modules, the maximum input power can reach  $2 \cdot P_n$ . For example, the maximum input power of the GW3600N-EH can reach 7200W.

\*2: For CEL 0-21.

\*3: The grid feed-in power for VDE-AR-N 4105 and NRS097-2-1 is limited to 4600VA.

\*4: CAN communication is configured by default. If 485 communication is used, please replace the corresponding communication cable.

\*5: No Backup Output.

\*6: Not all certifications & standards are listed, check the official website for details.

\*7: For Brazil, the voltage is 220V.

\*8: For Brazil, the current is 27.3A.

\*9: AFDPF: Active Frequency Drift with Positive Feedback, AQDPF: Active Q Drift with Positive Feedback.

\*10: 2000m for Australia.

Technical Data	GW3600-EH	GW5000-EH-BE	GW5000-EH	GW6000-EH
Battery Input Data				
Battery Type	Li-Ion	Li-Ion	Li-Ion	Li-Ion
Nominal Battery Voltage (V)	350	350	350	350
Battery Voltage Range (V)	85~460	85~460	85~460	85~460
Max. Continuous Charging Current (A)	25	25	25	25
Max. Continuous Discharging Current (A)	25	25	25	25
Max. Charge Power (W)	3600	5000	5000	6000
Max. Discharge Power (W)	3600	5000	5000	6000
PV String Input Data				
Max. Input Power (W)	4800	6650	6650	8000
Max. Input Voltage (V)	580	580	580	580
MPPT Operating Voltage Range (V)	100~550	100~550	100~550	100~550
MPPT Voltage Range at Nominal Power	150~550	210~550	210~550	250~550

<b>Technical Data</b>	<b>GW3600-EH</b>	<b>GW5000-EH-BE</b>	<b>GW5000-EH</b>	<b>GW6000-EH</b>
Start-up Voltage (V)	90	90	90	90
Nominal Input Voltage (V)	380	380	380	380
Max. Input Current per MPPT (A)	12.5	12.5	12.5	12.5
Max. Short Circuit Current per MPPT (A)	15.2	15.2	15.2	15.2
Max. Backfeed Current to The Array (A)	0	0	0	0
Number of MPP Trackers	2	2	2	2
Number of Strings per MPPT	1	1	1	1
<b>AC Output Data (On-grid)</b>				
Nominal Output Power (W)	3600	5000	5000	6000
Nominal Apparent Power Output to Utility Grid (VA) <sup>*3</sup>	3600	5000	5000	6000
Max. Apparent Power Output to Utility Grid (VA) <sup>*3</sup>	3600	5000	5000	6000
Nominal Apparent Power from Utility Grid (VA)	7200	10000	10000	12000

Technical Data	GW3600-EH	GW5000-EH-BE	GW5000-EH	GW6000-EH
Max. Apparent Power from Utility Grid (VA)	7200(Charging 3.6kw, Backup Output 3.6kw)	10000 (Charging 5kW, Backup Output 5kW)	10,000 (Charging 5kW, Backup Output 5kW)	12,000 (Charging 6kW, Backup Output 6kW)
Nominal Output Voltage (V)	230/220*5	230	230/220*5	230/220*5
Output Voltage Range (V)	0~300	0~300	0~300	0~300
Nominal AC Grid Frequency (Hz)	50/60	50/60	50/60	50/60
AC Grid Frequency Range (Hz)	45~65	45~65	45~65	45~65
Max. AC Current Output to Utility Grid (A)	16	21.7	21.7	26.1/27.3*6
Max. AC Current From Utility Grid (A)	32	43.4	43.4	52.2
Max. Output Fault Current (Peak and Duration) (A)	65A@5us	65A@5us	65A@5us	65A@5us
Inrush Current (Peak and Duration) (A)	65A@5us	65A@5us	65A@5us	65A@5us
Nominal Output Current (A)	15.6	21.7	21.7	26.1
Power Factor	Adjustable from 0.8 leading to 0.8 lagging			
Max. Total Harmonic Distortion	<3%	<3%	<3%	<3%

Technical Data	GW3600-EH	GW5000-EH-BE	GW5000-EH	GW6000-EH
Maximum Output Overcurrent Protection (A)	40	54	54	65
AC Output Data (Back-up)				
Back-up Nominal Apparent Power (VA)	3600	5000	5000	6000
Max. Output Apparent Power without Grid(VA)	3600 (43200@60sec)	5000 (6000@60sec)	5000 (6000@60sec)	6000 (7200@60sec)
Nominal Output Current (A)	15.7	21.7	21.7	26.1
Max. Output Current (A)	15.7	21.7	21.7	26.1
Max. Output Fault Current (Peak and Duration) (A)	19@60s	26@60s	26@60s	31@60s
Inrush Current (Peak and Duration) (A)	65@5us	65A@5us	65A@5us	A@5us
Maximum Output Overcurrent Protection (A)	16	21.7	21.7	26.1
Nominal Output Voltage (V)	230(±2%)	230(±2%)	230(±2%)	230(±2%)
Nominal Output Frequency (Hz)	50/60(+0.2%)	50/60(+0.2%)	50/60(+0.2%)	50/60(+0.2%)
Output THDv (@Linear Load)	<3%	<3%	<3%	<3%

Technical Data	GW3600-EH	GW5000-EH-BE	GW5000-EH	GW6000-EH
Efficiency		50/60(+0.2%)		
Max. Efficiency	97.6%	97.6%	97.6%	97.6%
European Efficiency	97.0%	97.0%	97.0%	97.0%
Max. Battery to AC Efficiency	96.6%	96.6%	96.6%	96.6%
MPPT Efficiency	99.9%	99.9%	99.9%	99.9%
Protection				
PV Insulation Resistance Detection	Integrated	Integrated	Integrated	Integrated
Residual Current Monitoring	Integrated	Integrated	Integrated	Integrated
Battery Reverse Polarity Protection	Integrated	Integrated	Integrated	Integrated
Anti-islanding Protection	Integrated	Integrated	Integrated	Integrated
AC Overcurrent Protection	Integrated	Integrated	Integrated	Integrated
AC Short Circuit Protection	Integrated	Integrated	Integrated	Integrated
AC Overvoltage Protection	Integrated	Integrated	Integrated	Integrated
General Data				
Operating Temperature Range (°C)	-25~+60	-25~+60	-25~+60	-25~+60
Relative Humidity	0~95%	0~95%	0~95%	0~95%

<b>Technical Data</b>	<b>GW3600-EH</b>	<b>GW5000-EH- BE</b>	<b>GW5000-EH</b>	<b>GW6000-EH</b>
Max. Operating Altitude (m)	3000*8	3000*8	3000*8	3000*8
Cooling Method	Natural Convection	Natural Convection	Natural Convection	Natural Convection
User Interface	LED, APP	LED, APP	LED, APP	LED, APP
Communication with BMS*4	RS485, CAN	RS485, CAN	RS485, CAN	RS485, CAN
Communication with Meter	RS485	RS485	RS485	RS485
Communication with Portal	WiFi / Ethernet (Optional)	WiFi / Ethernet (Optional)	WiFi / Ethernet (Optional)	WiFi / Ethernet (Optional)
Weight (kg)	17	17	17	17
Dimension (WxHxD mm)	354x433x147	354x433x147	354x433x147	354x433x147
Noise Emission (dB)	<35	<35	<35	<35
Topology	Non-isolated	Non-isolated	Non-isolated	Non-isolated
Self-consumption at Night (W)*5	<10	<10	<10	<10
Ingress Protection Rating	IP65	IP65	IP65	IP65
DC Connector	MC4 (4~6 mm <sup>2</sup> )	MC4 (4~6 mm <sup>2</sup> )	MC4 (4~6 mm <sup>2</sup> )	MC4 (4~6 mm <sup>2</sup> )
AC Connector	Quick Plug	Quick Plug	Quick Plug	Quick Plug
Environmental Category	4K4H	4K4H	4K4H	4K4H

Technical Data	GW3600-EH	GW5000-EH- BE	GW5000-EH	GW6000-EH
Pollution Degree	III	III	III	III
Overvoltage Category	DC II / AC III	DC II / AC III	DC II / AC III	DC II / AC III
Protective Class	I	I	I	I
Storage Temperature (°C)	-40~+85	-40~+85	-40~+85	-40~+85
The Decisive Voltage Class (DVC)	Battery: C PV: C AC: C Com: A	Battery: C PV: C AC: C Com: A	Battery: C PV: C AC: C Com: A	Battery: C PV: C AC: C Com: A
Mounting Method	Wall Mounted	Wall Mounted	Wall Mounted	Wall Mounted
Active Anti-islanding Method	AFDPF+ AQDPF*7	AFDPF+ AQDPF*7	AFDPF+ AQDPF*7	AFDPF+ AQDPF*7
Type of Electrical Supply System	Single phase TN/TT system	Single phase TN/TT system	Single phase TN/TT system	Single phase TN/TT system
Country of Manufacture	China	China	China	China
Certification*4				
Grid Standards	VDE-AR-N 4105, G98, G100, CEI 0-21,AS/NZS477.2, NRS097-2-1			
Safety Regulation	IEC/EN 62109-1&2			
EMC	EN61000-6-1, EN61000-6-2, EN61000-6-3, EN61000-6-4,EN 61000-4-16,EN 61000-4-18, EN 61000-4-29			

\*1: The grid feed-in power for VDE-AR-N 4105 and NRS097-2-1 is limited to 4600VA.

\*2: CAN communication is configured by default. If 485 communication is used,

please replace the corresponding communication cable.

\*3: No Backup Output.

\*4: Not all certifications & standards are listed, check the official website for details.

\*5: For Brazil, the voltage is 220V.

\*6: For Brazil, the current is 27.3A.

\*7: AFDPF: Active Frequency Drift with Positive Feedback, AQDPF: Active Q Drift with Positive Feedback.

\*8: 2000m for Australia.