

V1.5-2026-04-15

Grid-Tied PV Inverter

MS Series (7-10kW) G4
User Manual

GOODWE

Copyright Statement

Copyright© GoodWe Technologies Co., Ltd. 2026. All rights reserved.

Without the authorization of GoodWe Technologies Co., Ltd., no part of this manual may be reproduced, disseminated, or uploaded to public networks or other third-party platforms in any form.

Trademark Authorization

GOODWE and other GOODWE trademarks used in this manual are the property of GoodWe Technologies Co., Ltd. All other trademarks or registered trademarks mentioned in this manual are the property of their respective owners.

NOTICE

Due to product version upgrades or other reasons, the content of this document is updated from time to time. Unless otherwise agreed, the content of this document cannot replace the safety precautions on the product label. All descriptions in this document are for guidance only.

About This Manual

This document primarily introduces the product information, installation and wiring, configuration and commissioning, troubleshooting, and maintenance of the inverter. Please read this manual carefully before installing and using this product to understand the product safety information and familiarize yourself with the product's functions and features. The document may be updated periodically; please obtain the latest version and more product information from the official website.

Applicable Model

This document is applicable to the following inverter models:

model	Nominal output power	Nominal output voltage
GW7K-MS-CN-G40	7kW	220V, L/N/PE
GW8K-MS-CN-G40	8kW	
GW10K-MS-CN-G40	10kW	
GW7.5K-MS-G40	7.5kW	220V/230V/240V, L/N/PE
GW8.5K-MS-G40	8.5kW	
GW9.999K-MS-G40	9.999kW	
GW10K-MS-G40	10kW	
GW7.5K-MS-G41	7.5kW	220V/230V, L/N/PE
GW8K-MS -G40	8kW	

Applicable Personnel

Only applicable to professionals familiar with local regulations and standards,

electrical systems, professionally trained, and knowledgeable about this product.

Symbol Definition

To better use this manual, the manual uses the following symbols to highlight important information. Please carefully read the symbols and explanations.





 DANGER
Indicates a high potential hazard that, if not avoided, will result in death or serious injury.
 WARNING
Indicates a moderate potential hazard that, if not avoided, could result in death or serious injury.
 CAUTION
Indicates a low potential hazard that, if not avoided, could result in moderate or minor injury.
 NOTICE
Emphasizes and supplements the content, and may also provide tips or tricks for optimizing product use, helping you solve a problem or save time.

Table of Contents

1 Safety Precautions	7
1.1 General Safety	7
1.2 DC side	7
1.3 AC side	8
1.4 Inverter	8
1.5 EU Declaration of Conformity	9
1.5.1 Equipment with Wireless Communication Modules	10
1.5.2 No Equipment with Wireless Communication Modules	10
1.6 personnel requirements	10
2 Product Introduction	12
2.1 Introduction	12
2.2 Circuit Block Diagram	13
2.3 Supported Grid Types	14
2.4 Features	15
2.5 Appearance Description	16
2.5.1 Component Introduction	16
2.5.2 Product dimensions	17
2.5.3 Nameplate description	18
2.5.4 indicator Description	19
3 Check and Storage	21
3.1 Check Before Receiving	21

3.2 deliverables	21
3.3 Storage	23
4 Installation	24
4.1 Installation Requirements	24
4.2 Installing the Inverter	26
4.2.1 Handling Inverter	27
4.2.2 Installing the Inverter	27
5 Electrical connection	29
5.1 Safety Precautions	29
5.2 Connecting the PE cable	29
5.3 Connect AC output cables	30
5.4 Connect the DC input cable	33
5.5 Communication connection	35
5.5.1 Introduction to Communication Networking	36
5.5.2 Connection Communication cable	39
6 Equipment trial operation	45
6.1 Check Before Power ON	45
6.2 Equipment power on	45
7 System Commissioning	47
7.1 indicator Description	47
7.2 Set the Inverter parameters via the display screen	47
7.2.1 Introduction to Display Screen Menu	49

7.3 Set Inverter parameters via the App	51
7.4 Download SEMS+ APP	51
8 Maintenance	53
8.1 Inverterpower off	53
8.2 dismantleInverter	53
8.3 Scrap Inverter	53
8.4 Inverter fault	54
8.4.1 Troubleshooting (fault code F01-F40)	54
8.4.2 Troubleshooting (fault code F41-F80)	70
8.4.3 Troubleshooting (fault code F81-F121)	79
8.4.4 Troubleshooting (fault code F122-F163)	91
8.4.5 fault phenomenon handling	99
8.5 Routine Maintenance	117
9 Inverter Parameters	119
10 Explanation of Terms	129
11 Related product manuals acquisition	131

1 Safety Precautions

WARNING

The inverter has been strictly designed and tested in accordance with safety regulations, but as an electrical device, relevant safety instructions must be followed before performing any operations on the device. Improper operation may lead to serious injury or property damage.

1.1 General Safety

NOTICE

- Due to product version upgrades or other reasons, the content of this document is updated periodically. Unless otherwise agreed, the document content cannot replace the safety precautions on the product label. All descriptions in this document are for guidance only.
- Please read this document carefully before installing the equipment to understand the product and its precautions.
- All operations on the equipment must be performed by professional and qualified electrical technicians who are familiar with the relevant standards and safety regulations in the project location.
- When operating the equipment, use insulated tools and wear personal protective equipment to ensure personal safety. When touching electronic components, wear anti-static gloves, anti-static wrist straps, anti-static clothing, etc., to protect the equipment from electrostatic damage.
- Unauthorized disassembly or modification may cause equipment damage, which is not covered by the warranty.
- Equipment damage or personal injury caused by failure to install, use, or configure the equipment in accordance with the requirements of this document or the corresponding user manual is beyond the manufacturer's liability. For more product warranty information, please visit the official website: <https://en.goodwe.com/warrantyrelated.html>.

1.2 DC Side

DANGER

Use the DC connector supplied with the unit to connect the inverter DC cables. Using other models of DC connectors may lead to serious consequences, and any resulting equipment damage is beyond the manufacturer's liability.

 **WARNING**

- Ensure the component frame and mounting system are properly grounded.
- After connecting the DC cables, ensure the connections are secure and not loose.
- When measuring the PV string with a multimeter, damage caused by reverse connection, overvoltage, or overcurrent is beyond the manufacturer's liability.
- Photovoltaic modules connected to the same MPPT must be of the same model. The voltage difference between different MPPTs must be <160V.
- When the input voltage is between 1000V~1100V, the inverter will enter standby mode. The inverter will resume normal operation when the voltage returns to the MPPT operating voltage range (140V~1000V).
- It is recommended that the sum of the peak power currents of the strings connected to each MPPT does not exceed the maximum input current per MPPT of the inverter.
- When the inverter is connected to multiple PV strings, it is recommended to connect at least one string per MPPT, with no MPPT left unconnected.
- Photovoltaic modules used with the inverter must comply with the IEC 61730 Class A standard.

1.3 AC Side









 **WARNING**

- Ensure that the voltage and frequency at the grid connection point comply with the inverter's grid connection specifications.
- It is recommended to add protective devices such as circuit breakers or fuses on the AC side of the inverter. The rating of the protective devices should be greater than 1.25 times the maximum output current of the inverter.
- The protective ground wire of the inverter must be securely connected.
- It is recommended to use copper-core cables for AC output lines. If aluminum wires are to be used, please use copper-aluminum transition terminals for connection.

1.4 Inverter

⚠ DANGER

- During inverter installation, avoid placing weight on the bottom terminals, as this may cause terminal damage.
- After inverter installation, the labels and warning signs on the enclosure must remain clearly visible. Do not cover, alter, or damage them.
- Use only the connectors supplied with the unit to connect the inverter cables. Using connectors of other models may lead to serious consequences, and any resulting equipment damage is not covered by the manufacturer's warranty.
- The warning labels on the inverter enclosure are as follows:

No.	Symbol	Meaning
1		High voltage hazard. High voltage is present when the inverter is operating. Ensure the inverter is powered off before performing any operations on it.
2		Delayed discharge. After powering off the device, wait for 5 minutes for the device to fully discharge.
3		Read the product manual carefully before operating the inverter.
4		Potential hazard exists after the device starts running. Take necessary precautions during operation.
5		The inverter surface is at high temperature. Do not touch it while the device is operating, as it may cause burns.
6		Grounding point.
7		CE certification mark.
8		This device must not be disposed of as household waste. Dispose of the device according to local laws and regulations, or return it to the manufacturer.
9		RCM mark.

1.5 EU Declaration of Conformity

1.5.1 Equipment with Wireless Communication Modules

Growatt Technology Co., Ltd. hereby declares that the Equipment with Wireless Communication Modules available for sale in the European market complies with the requirements of the following directives:

- Radio Equipment Directive 2014/53/EU (RED)
- Restrictions of Hazardous Substances Directive 2011/65/EU and (EU) 2015/863 (RoHS)
- Waste Electrical and Electronic Equipment 2012/19/EU
- Registration, Evaluation, Authorization and Restriction of Chemicals (EC) No 1907/2006 (REACH)

1.5.2 Devices without wireless communication functionality

GoodWe Technologies Co., Ltd. hereby declares that the devices without wireless communication functionality sold in the European market comply with the requirements of the following directives:

- Electromagnetic compatibility Directive 2014/30/EU (EMC)
- Electrical Apparatus Low Voltage Directive 2014/35/EU (LVD)
- Restrictions of Hazardous Substances Directive 2011/65/EU and (EU) 2015/863 (RoHS)
- Waste Electrical and Electronic Equipment 2012/19/EU
- Registration, Evaluation, Authorization and Restriction of Chemicals (EC) No 1907/2006 (REACH)

More EU Declarations of Conformity can be obtained from the official website:
<https://en.goodwe.com>.

1.6 personnel requirements

NOTICE

- Personnel responsible for the installation and maintenance of the equipment must first undergo rigorous training to understand all product safety precautions and master the correct operating procedures.
- Installation, operation, maintenance, and replacement of equipment or components are only permitted to be performed by qualified professionals or trained personnel.

2 Product Introduction

2.1

Introduction

MS Series Inverters are single-phase string photovoltaic grid-connected inverters. The inverters convert the direct current generated by photovoltaic solar panels into alternating current that meets grid requirements and feed it into the grid. The main application scenarios for the inverters are as follows:

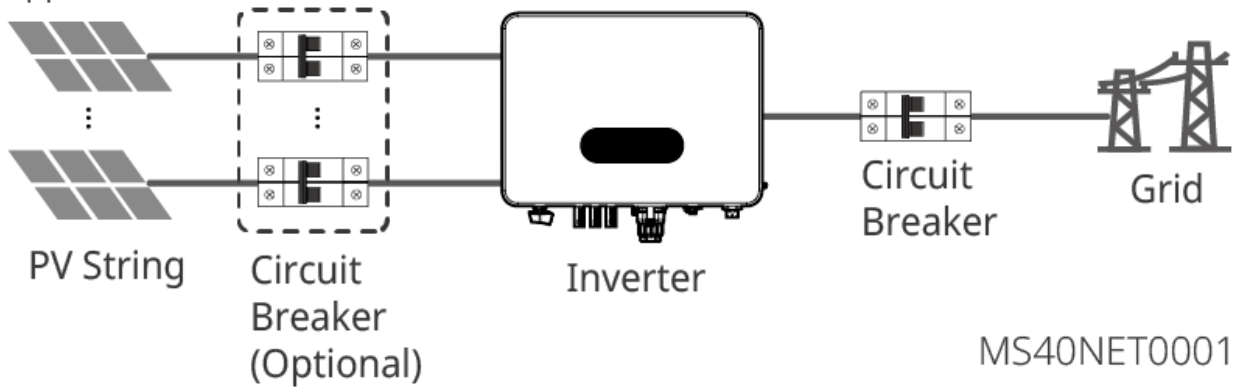

Model Number Meaning

GW10K-MS-CN-G40

No.	Meaning	Description
2	Rated Power	10K: Rated power is 10kW 8K: Rated power is 8kW 7K: Rated power is 7kW
3	Series code	MS: MS Series
4	Special Country Code	CN: China Version
5	Version code	G40: Fourth Generation Product

GW10K-MS-G40

1 2 3 4

MS40DSC0007

No.	Meaning	Description
1	Brand code	GW: GoodWe
2	Rated Power	10K: Rated Power is 10kW 9.999K: Rated Power is 9.999kW 8.5K: Rated Power is 8.5kW 8K: Rated Power is 8kW 7.5K: Rated Power is 7.5kW
3	Series code	MS: MS Series
4	Version code	G40/G41: Fourth Generation Product

2.2 Circuit Block Diagram

GW7.5K-MS-G40, GW8.5K-MS-G40, GW10K-MS-G40, GW9.999K-MS-G40:

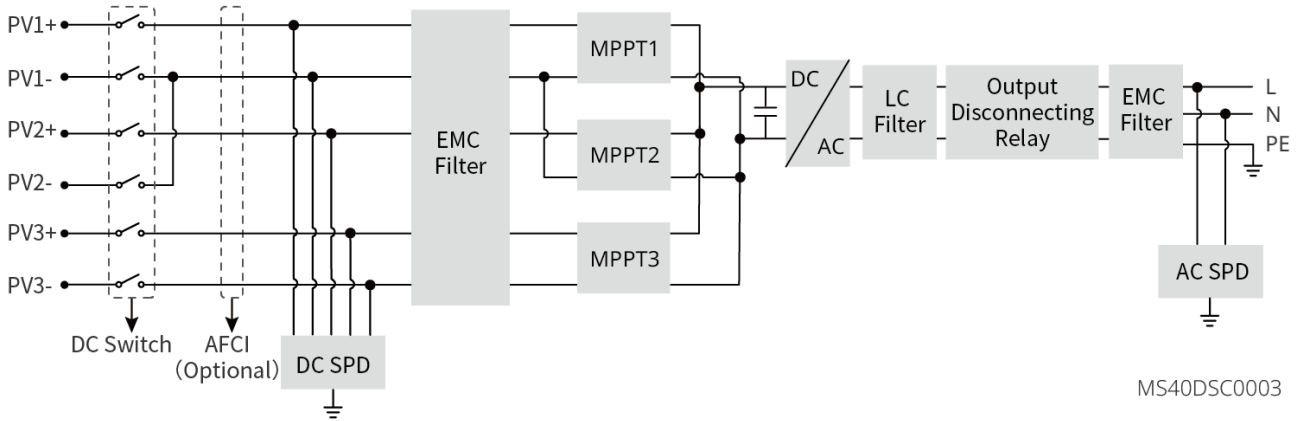

GW7.5K-MS-G41, GW8K-MS-G40, GW7K-MS-CN-G40, GW8K-MS-CN-G40, GW10K-MS-CN-G40:

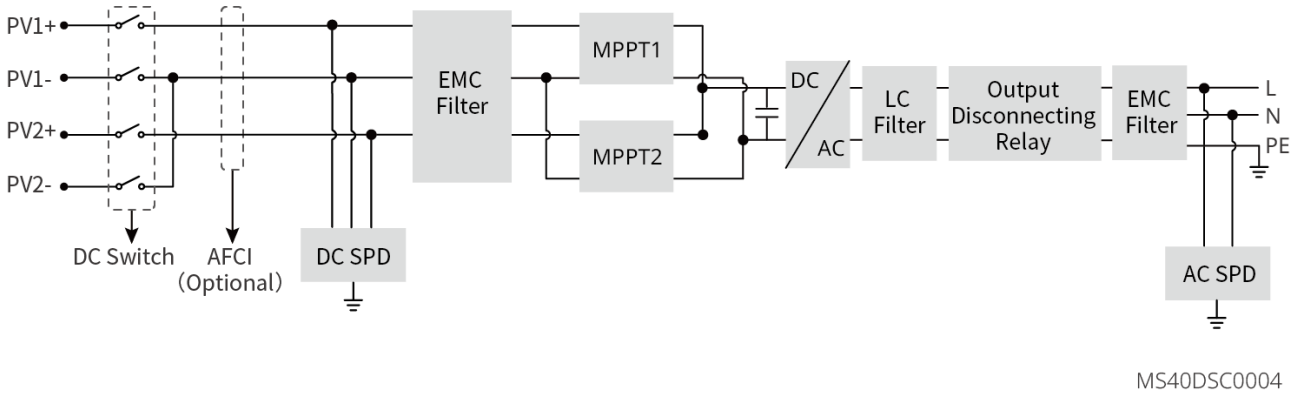

2.3 Supported Grid Types

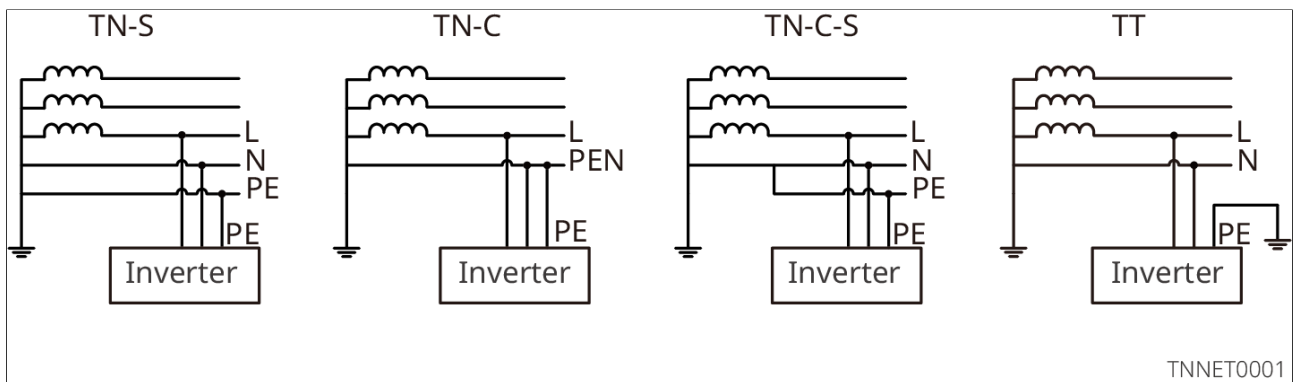

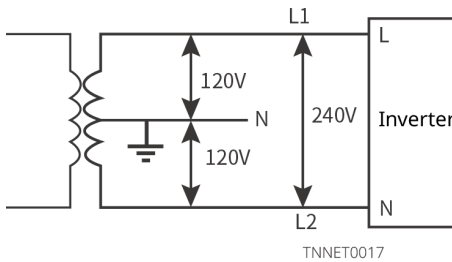

2.4 Features

NOTICE

Specific feature configurations are subject to the actual model.

AFCI

The AFCI function is used to detect arc faults on the DC side of the inverter. When an arc fault occurs, the inverter will automatically engage protection.

Causes of arc faults:

- Damage or improper connection of DC connectors in the PV system.
- Incorrect or damaged cable connections.
- Aging of connectors or cables.

Communication

The inverter supports parameter configuration via Bluetooth for local settings; it also supports connection to a monitoring platform via WiFi, LAN, or 4G to monitor the inverter's operating status, power plant performance, etc.

- Bluetooth: Complies with the Bluetooth 5.1 standard.
- WiFi/LAN2.0 (Optional): Wireless IEEE 802.11 b/g/n @2.4 GHz; Ethernet 10M/100Mbps auto-negotiation; if a third-party monitoring platform is to be used, that platform must support the ModbusTCP communication protocol.
- 4G (Optional): Supports connection to a third-party monitoring platform via the MQTT communication protocol.

No.	Component/Silkscreen	Description
2	PV input terminals	Can connect the DC input cables from PV modules. GW7.5K-MS-G40, GW8.5K-MS-G40, GW10K-MS-G40, GW9.999K-MS-G40: PV+/PV- x 3. GW7.5K-MS-G41, GW8K-MS-G40, GW7K-MS-CN-G40, GW8K-MS-CN-G40, GW10K-MS-CN-G40: PV+/PV- x 2.
3	Communication Port	Can connect communication cables for load control, optional CT, RS485 (meter), Remote Shutdown, DRED (Australia)/RCR (Europe), etc.
4	Communication module port	Can connect communication modules, such as 4G, WiFi/LAN, etc. Please select the module type according to actual needs. Supports connecting a U disk for local inverter software version upgrade. For the Brazilian market, can connect a USB-RS485 adapter cable.
5	Ventilation valve	-
6	AC output cable terminals	Can connect AC output cables to link the inverter to the grid.
7	indicator	Indicates the working status of the inverter.
8	Display and buttons	<ul style="list-style-type: none"> • View inverter-related data. • GW7K-MS-CN-G40, GW8K-MS-CN-G40, GW10K-MS-CN-G40, optional. • GW7.5K-MS-G40, GW8.5K-MS-G40, GW9.999K-MS-G40, GW10K-MS-G40, GW7.5K-MS-G41, GW8K-MS-G40, standard-equipped. • Used to operate the display.
9	Grounding terminal	Connecting the PE cable.
10	heat sink	Inverter heat dissipation.
11	Mounting bracket	Can mount the inverter.

2.5.2 Product Dimensions

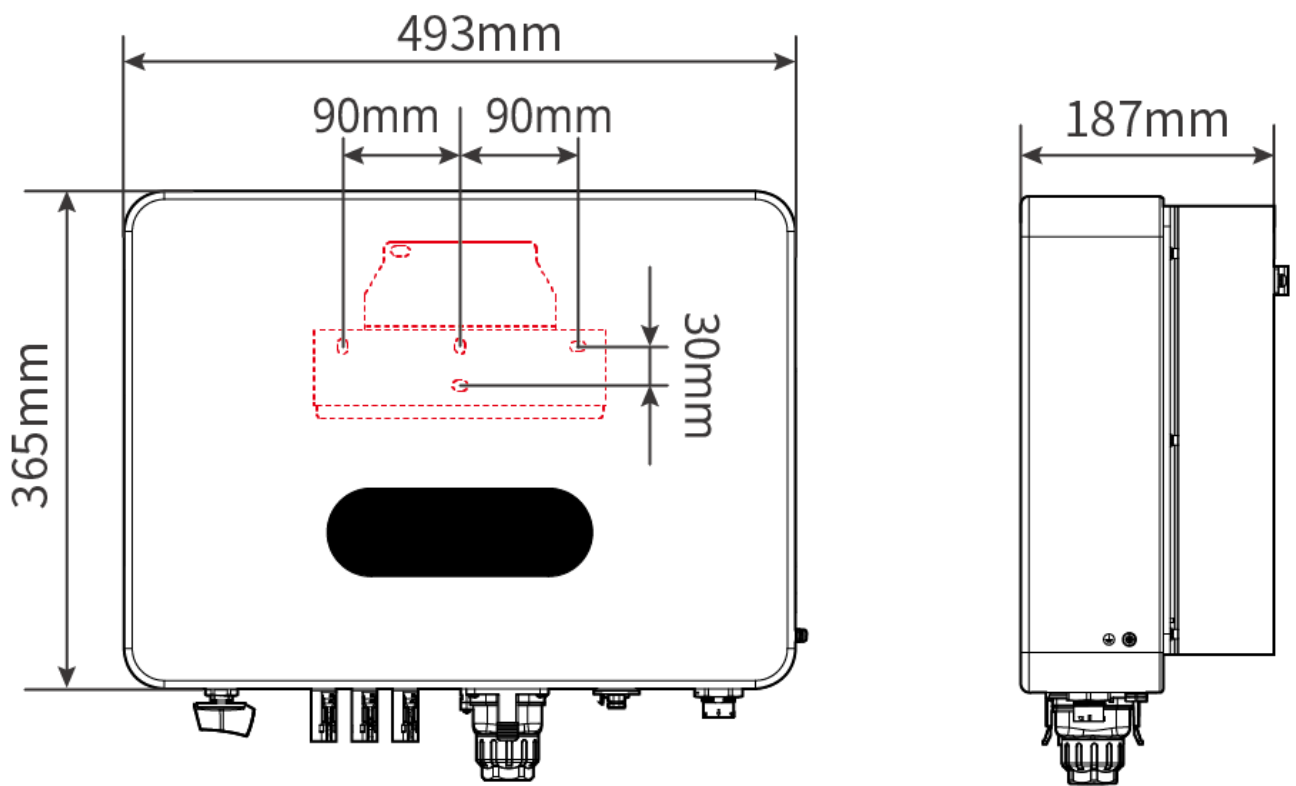







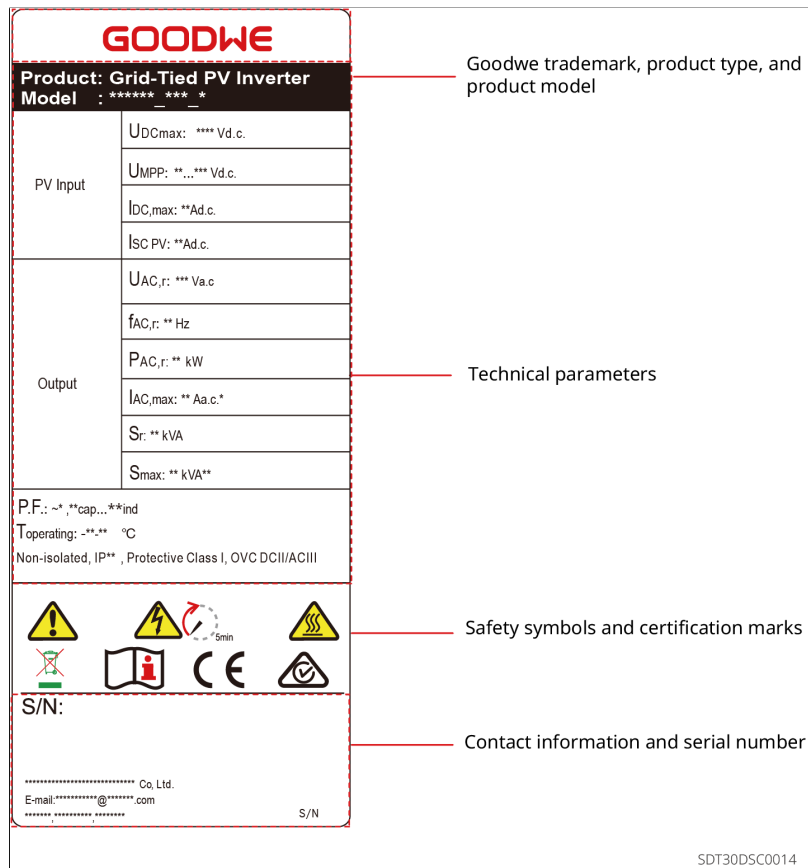

MS40DSC0006



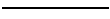



2.5.3 Nameplate Instructions

The nameplate is for reference only; please refer to the actual product.

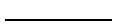

2.5.4 Indicator Light Instructions

Indicator	Status	Description
 Power		Steady on: Device powered on
		Off: Device not powered
 Run		Steady on: Grid normal, grid connection successful
		Off: Not connected to grid
		Single slow flash: Self-check before grid connection
		Single fast flash: About to connect to grid
		Steady on: Wireless monitoring normal

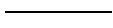
 Communi cation		Single flash: Wireless module reset or reconfigured
		Two flashes: Not connected to base station or router
		Four flashes: Not connected to monitoring server
		Flashing: RS485 communication normal
		Off: Wireless module restoring factory settings
 Fault		Steady on: System fault
		Off: No fault

3 Check and Storage

3.1 Check Before Receiving

Before receiving the product, please carefully check the following:

1. Check if the outer packaging is damaged, such as deformation, holes, cracks, or other signs that might cause damage to the equipment inside the packaging. If damaged, do not open the packaging and contact your dealer.
2. Check if the inverter model is correct. If not, do not open the packaging and contact your dealer.
3. Check if the type and quantity of delivered items are correct, and if there is any damage to the appearance. If damaged, contact your dealer.





3.2 deliverables



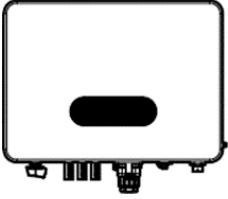
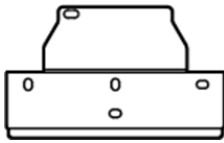
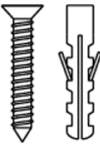
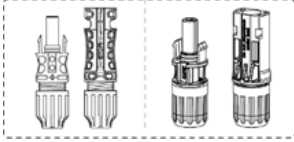
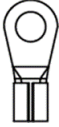

WARNING

When making electrical connections, please use the terminal blocks shipped with the unit. Damage to the equipment caused by using incompatible connectors will not be covered under warranty.

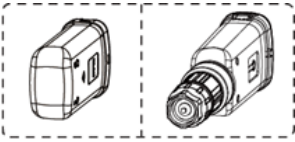
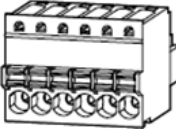
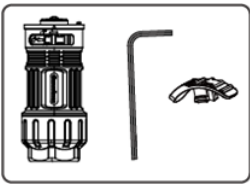
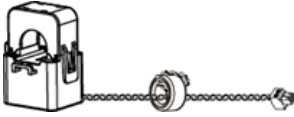
NOTICE

- [1] The quantity of DC connectors matches the number of DC terminals on the inverter. Please confirm based on the inverter's DC terminal count.
- [2] Communication module types include: WiFi/LAN, 4G, etc. The actual shipped type depends on the selected inverter communication method.
- [3] The quantity of communication terminals and tubular terminals matches the selected communication method; please confirm according to the communication configuration. Depending on the inverter configuration, the number of 2PIN communication terminals and DRED/RCR communication terminals included in the box varies. Please refer to the actual shipment.
- [4] Protocol converter connection cables are only shipped to China.
- [5] CT is standard in Australia and optional in other regions.
- [6] For China: x 0; for other regions: x 1.

Component	Description	Component	Description
	Inverter x1		mounting plate x1
	Expansion screw x 4		PV terminal ^[1] GW7.5K-MS-G40, GW8.5K-MS-G40, GW10K-MS-G40, GW9.999K-MS-G40: x 3 GW7.5K-MS-G41, GW8K-MS-G40, GW7K- MS-CN-G40, GW8K-MS- CN-G40, GW10K-MS- CN-G40: x 2
	Grounding OT terminal x 1		2PIN communication terminal x N ^[3]
	6PIN 485 communication terminal x 1		PIN terminal x N ^[3]
	smart dongle x 1 ^[2]		DRED/RCR communication terminal x N ^[3]
	<ul style="list-style-type: none"> AC terminal x 1 Hexagon screwdriver x 1 AC terminal unlocking tool x 1		(Optional) CT x 1 ^[5]

Component	Description	Component	Description
	Protocol converter connection cable (inverter side) x 1 ^[4]		Protocol converter connection cable (protocol converter side) x 1 ^[4]
	Product documentation x 1		PV unlocking tool x N ^[6]

3.3 Storage

If the device is not immediately put into use, store it according to the following requirements:

1. Ensure the outer packaging is not removed and the desiccant inside the box is not lost.
2. Ensure the storage environment is clean, with appropriate temperature and humidity ranges, and free from condensation.
3. Ensure the stacking height and orientation of inverters are arranged according to the instructions on the packaging label.
4. Ensure there is no risk of tipping after the inverters are stacked.
5. If the storage period of the inverter exceeds two years or it remains idle for more than 6 months after installation, it is recommended to have it inspected and tested by professionals before putting it into use.
6. To ensure the good electrical performance of the internal electronic components of the inverter, it is recommended to power it on every 6 months during storage. If it has not been powered on for more than 6 months, it is recommended to have it inspected and tested by professionals before putting it into use.

4 Installation

4.1 Installation Requirements

Installation Environment Requirements

1. The device must not be installed in flammable, explosive, corrosive, or similar environments.
2. The installation carrier must be sturdy and reliable, capable of bearing the weight of the inverter.
3. The installation space must meet the device's ventilation and heat dissipation requirements, as well as operational space requirements.
4. The device's protection rating must be suitable for indoor and outdoor installation, and the installation environment temperature and humidity must be within the appropriate range.
5. The inverter should avoid installation environments with direct sunlight, rain, snow accumulation, etc. It is recommended to install it in a sheltered location; if necessary, a sunshade can be constructed.
6. The installation location must be out of reach of children and avoid easily accessible spots. The device surface may become hot during operation to prevent burns.
7. The device installation height should facilitate operation and maintenance, ensuring that device indicators, all labels are easily visible, and wiring terminals are easy to operate.
8. The inverter installation altitude should be below the maximum operating altitude of 4000m.
9. Inverters installed in salt damage areas may be subject to corrosion. Salt damage areas refer to regions within 1000m of the coast or affected by sea breeze. The areas affected by sea breeze vary depending on meteorological conditions (e.g., typhoons, seasonal winds) or terrain (with embankments, hills).
10. Stay away from strong magnetic field environments to avoid electromagnetic interference. If there are radio stations or wireless communication devices below 30MHz near the installation location, please install the device according to the following requirements:
 - Add multi-turn winding ferrite cores at the inverter's DC input lines or AC output lines, or add low-pass EMI filters.
 - The distance between the inverter and wireless electromagnetic interference devices should exceed 30m.

Installation Carrier Requirements

- The installation carrier must not be made of flammable materials and must have fire-resistant properties.
- Ensure that the installation surface is sturdy, guaranteeing that the carrier meets the device's load-bearing requirements.
- During operation, the device may produce vibrations. Do not install it on carriers with poor sound insulation to prevent noise from disturbing residents in living areas.



Installation Angle Requirements

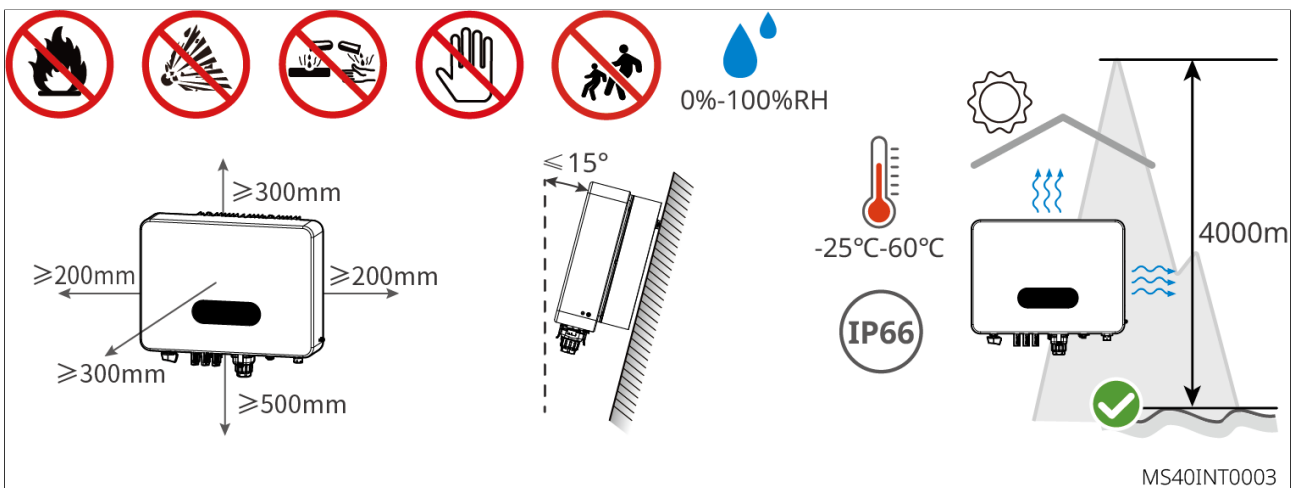





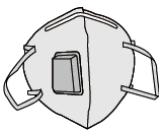

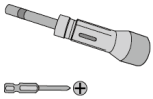
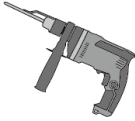

- Recommended inverter installation angle: vertical or tilted back $\leq 15^\circ$.
- Do not invert, tilt forward, tilt back beyond the angle, or install the inverter horizontally.

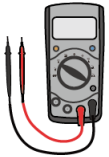
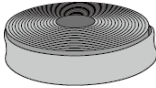

Installation Tool Requirements

During installation, it is recommended to use the following installation tools. If necessary, other auxiliary tools can be used on-site.

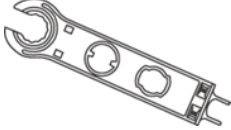
Tool Type	Description	Tool Type	Description
	Insulated gloves, protective gloves		Dust mask
	goggle		Safety shoes

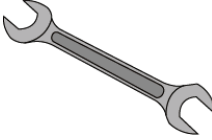
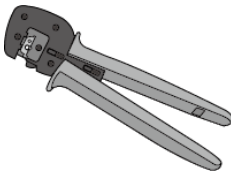
Tool Type	Description	Tool Type	Description
	torque wrench M3/M5		hammer drill
	diagonal plier		Heat gun
	wire stripper		Terminal crimping tool
	rubber hammer		Marker pen
	multimeter		Heat shrink tubing
	Vacuum cleaner		Level bar
 or 	DC unlocking tool		Wrench
	crimping tool	-	-

4.2 Installing the Inverter

4.2.1 Handling Inverter

CAUTION

Before installation, the inverter must be transported to the installation site. To avoid personal injury or equipment damage during transportation, please note the following:

1. Please allocate personnel according to the weight of the equipment to prevent the equipment from exceeding the weight limit that can be manually carried, which could cause injury.
2. Please wear safety gloves to avoid injury.
3. Please ensure the equipment remains balanced during transportation to prevent it from falling.

4.2.2 Installing the Inverter

NOTICE

- When drilling holes, ensure the drilling location avoids water pipes, cables, etc. inside the wall to prevent danger.
- When drilling holes, please wear safety goggles and a dust mask to avoid inhaling dust into the respiratory tract or getting it in the eyes.
- The DC switch lock is user-supplied(Australia only).
- The anti-theft lock is user-supplied. Please select a suitable anti-theft lock, otherwise installation may not be possible.
- Ensure the inverter is securely installed to prevent it from falling and causing injury.

1. Place the backplate horizontally against the wall and use a marker to mark the drilling positions.
2. Use an impact drill with a bit diameter of 8mm to drill the holes, ensuring a depth of approximately 45mm.
3. Secure the backplate to the wall or bracket using expansion screws.

4. Mount the inverter onto the backplate and secure the backplate to the inverter.
5. Install the anti-theft lock (hole diameter 8mm). Install the DC switch lock (Australia only) with a hole diameter of 5mm.

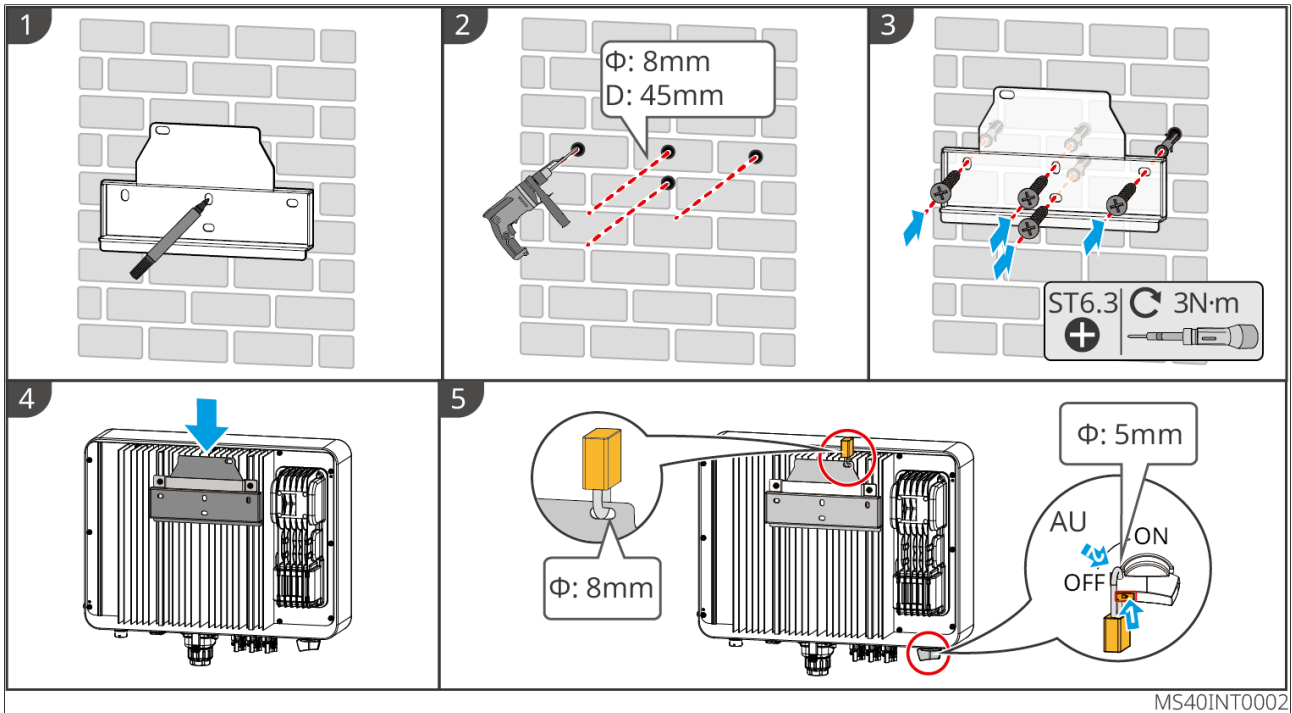

5 Electrical Connection

5.1 Safety Precautions

DANGER

- Before performing electrical connections, disconnect the inverter's DC switch and AC output switch to ensure the device is powered off. It is strictly prohibited to operate with power on, otherwise it may cause electric shock and other DANGER.
- All operations during electrical connections, as well as the specifications of cables and components used, must comply with local laws and regulations.
- If the cable is subjected to excessive tension, it may lead to poor connections. When wiring, please leave a certain length of cable before connecting it to the inverter's terminal ports.

NOTICE

- When performing electrical connections, wear personal protective equipment such as safety shoes, protective gloves, insulating gloves, etc., as required.
- Only professionals are allowed to perform electrical connection-related operations.
- The cable colors in the graphics of this document are for reference only; specific cable specifications must comply with local regulations.

5.2 Connecting the PE cable

WARNING

- The protective grounding of the chassis cannot replace the protective earth wire of the AC output port. During wiring, ensure the protective earth wires at both locations are reliably connected.
- When using multiple inverters, ensure the protective grounding points of all inverter chassis are connected at equal potential.
- To improve the corrosion resistance of the terminal, it is recommended to apply silicone sealant or paint to the exterior of the grounding terminal after installation of the protective earth wire connection is complete.
- Please prepare your own protective earth wire. Recommended specifications:
 - Type: Outdoor single-core copper wire
 - Conductor cross-sectional area: 4-6mm²

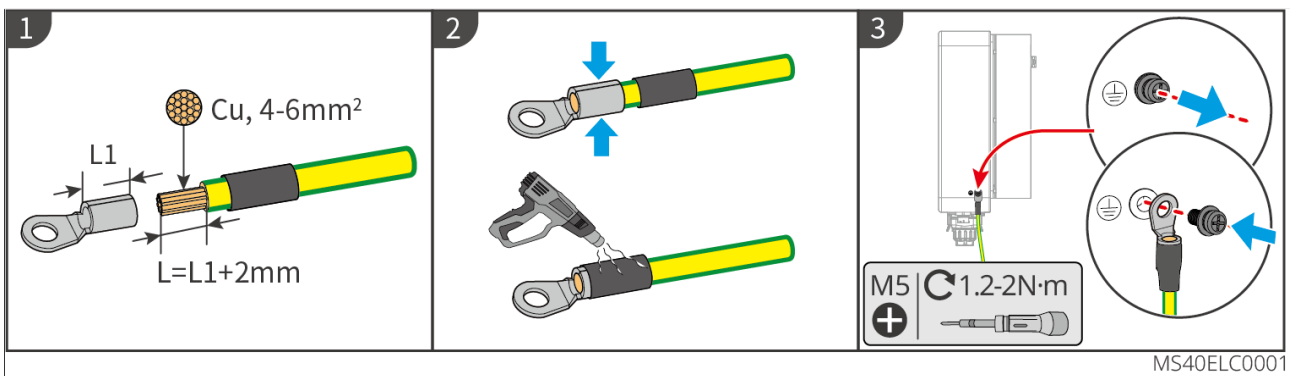

5.3 Connecting AC Output Cables

⚠ WARNING

- Do not connect loads between the inverter and the AC switch directly connected to the inverter.
- The inverter is equipped with an integrated Residual Current Monitoring Unit (RCMU). When the inverter detects leakage current exceeding the permissible value, it will quickly disconnect from the grid.

NOTICE

- Each inverter must be equipped with an AC output switch. Multiple inverters must not be connected to a single AC switch simultaneously.
- If the inverter's AC output terminals are not used, please seal the terminals with a waterproof cover. Otherwise, the equipment's protection rating will be affected.

To ensure that the inverter and grid can be safely disconnected in case of abnormalities, please connect an AC switch on the AC side of the inverter. Please select a suitable AC switch according to local regulations. The following switch specifications are for reference:

Inverter Model	AC Switch Specification
GW7K-MS-CN-G40	50A
GW8K-MS-CN-G40	50A
GW10K-MS-CN-G40	63A
GW7.5K-MS-G40	50A
GW8.5K-MS-G40	63A
GW9.999K-MS-G40	63A
GW10K-MS-G40	63A
GW7.5K-MS-G41	50A
GW8K-MS -G40	50A

Please decide whether to install an RCD device according to local laws and regulations.

The inverter can additionally be connected to an A type RCD (Residual Current Device), which provides protection when the DC component of leakage current exceeds the limit. It is recommended to use an RCD with a specification of 300mA (according to local regulations).

NOTICE

Each inverter must be equipped with an AC output switch. Multiple inverters cannot be connected to a single AC switch simultaneously.

 WARNING

- When connecting AC cables, always use tubular terminals for crimping.
- During wiring, ensure that the AC output wires match the L, N, PE ports of the AC terminal exactly. If the cables are connected incorrectly, it will cause inverter damage.
- Ensure that the wire cores are fully inserted into the AC terminal wiring holes, with no exposure.
- Ensure that the cable connections are tight. Otherwise, during equipment operation, it may cause the terminals to overheat and damage the inverter.

1. Prepare the AC output cable.
2. Disassemble the AC terminal, connect the AC output cable to the AC terminal. Assemble the AC terminal.
3. Connect the AC terminal to the inverter.

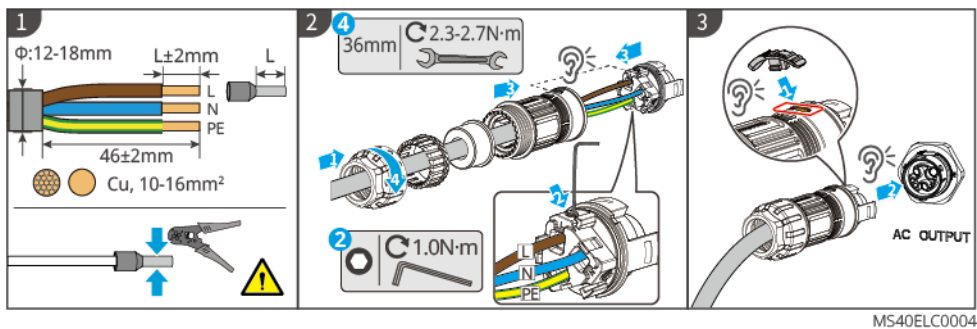

Disassembly of AC terminal

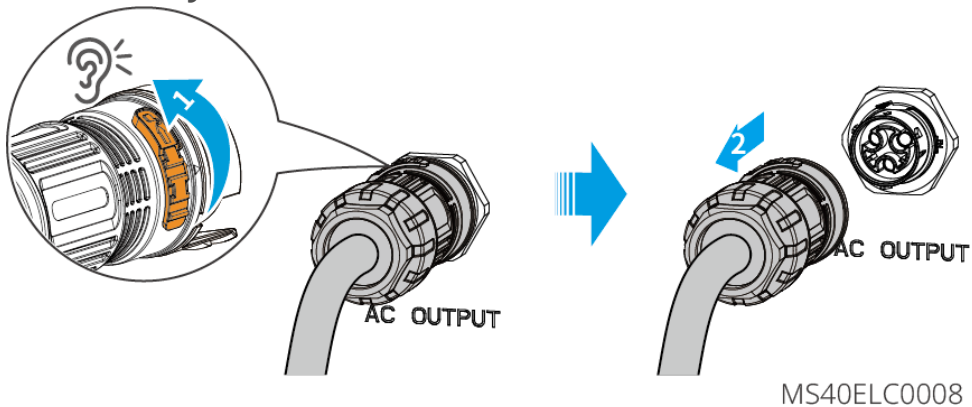

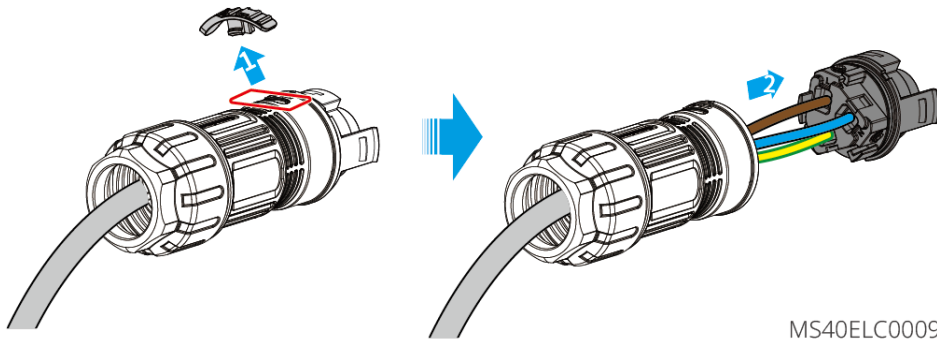

MS40ELC0009

NOTICE

- After completing the wiring connection, please check the correctness and firmness of the wiring, and clean up the construction residues.
- The AC output terminals must be sealed to ensure the machine's protection level.

5.4 Connecting DC Input Cables

DANGER

Before connecting the PV strings to the inverter, please confirm the following information. Otherwise, it may cause permanent damage to the inverter and, in severe cases, lead to fire, resulting in personal injury and property loss.

1. Ensure the maximum short-circuit current and maximum input voltage for each MPPT are within the inverter's allowable range.
2. Ensure the positive terminal of the PV string is connected to the inverter's PV+, and the negative terminal of the PV string is connected to the inverter's PV-.

WARNING

- Mixing PV modules of different brands or models within the same MPPT circuit, or connecting PV modules with different orientation angles or tilt angles in the same PV string, will not necessarily damage the inverter but may lead to reduced system performance.
- The maximum DC input voltage of the inverter is 600V. Please ensure the open-circuit voltage of the PV string connected to each MPPT circuit does not exceed 600V. When the input voltage is between 560V-600V, the inverter will enter standby mode. It will resume normal operation when the voltage returns to the MPPT operating voltage range of 40V-560V.
- It is recommended that the voltage difference between different MPPT circuits does not exceed 150V.
- The sum of the peak power currents of the strings connected to each MPPT circuit must not exceed the Max. Current from Grid of the inverter for each MPPT circuit.
- When the inverter is connected to multiple PV strings, it is recommended to maximize the number of MPPTs being utilized.
- PV string output does not support grounding. Before connecting the PV string to the inverter, please ensure the minimum insulation resistance to ground of the PV string meets the minimum insulation impedance requirement.
- Please provide your own DC input cables.

NOTICE

If the inverter DC input terminals do not need to connect to the PV string, please use a waterproof cover to seal the terminals, otherwise it will affect the equipment protection rating.

Connecting DC Input Cables

1. Prepare the DC cables.
2. Crimp the DC input terminals and assemble the DC connectors.
3. Tighten the DC connectors.
4. Check the DC input voltage.
5. Connect the DC connectors to the inverter's DC terminals.

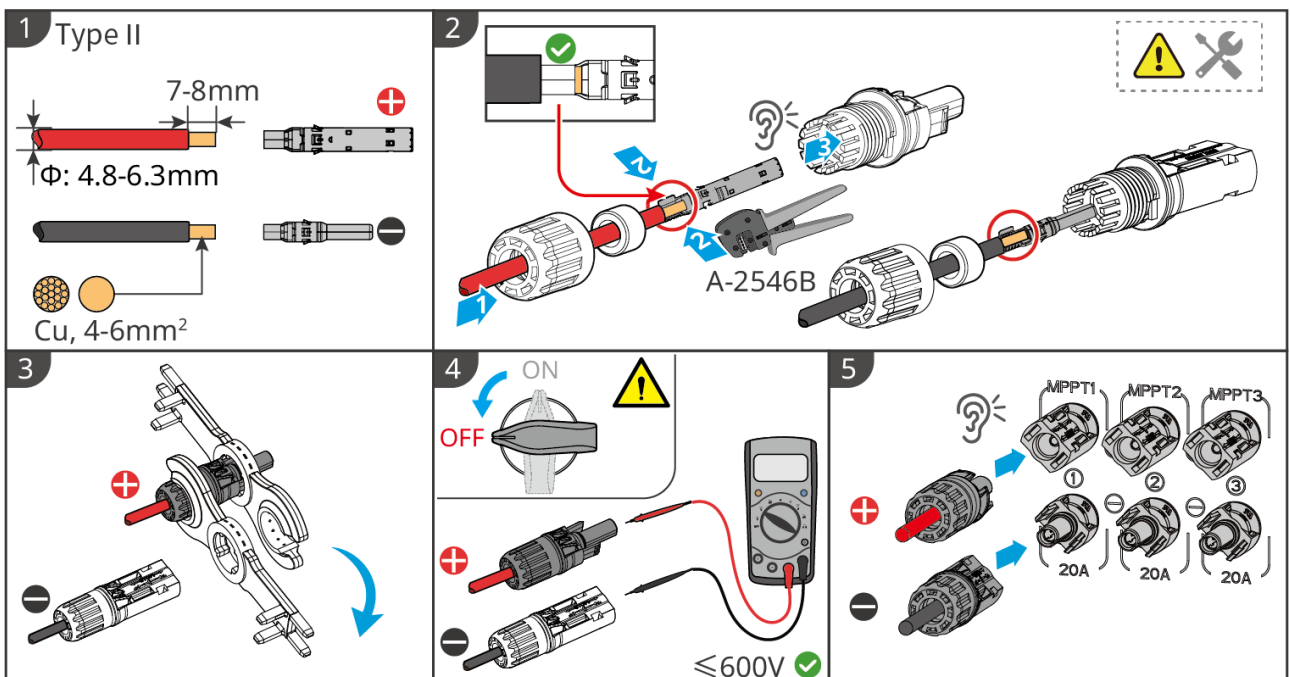
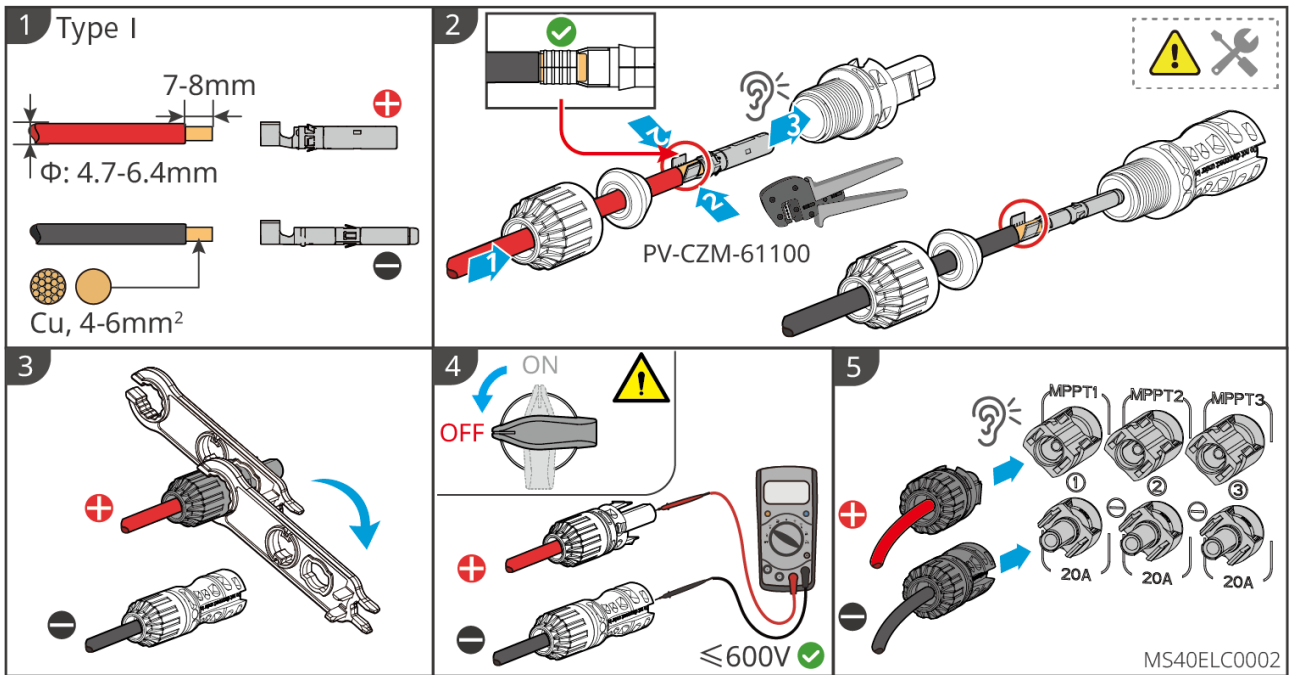

5.5 Communication Connection

NOTICE

- For specific product feature configurations, please refer to the actual inverter model in your region.
- Due to product version upgrades or other reasons, document content is updated periodically. For the compatibility relationship between inverters and IoT products, please refer to:
https://en.goodwe.com/Ftp/EN/Downloads/User%20Manual/GW_Compatibility-list-of-GoodWe-inverters-and-IoT-products-EN.pdf

5.5.1 Communication Networking Introduction

Power Limiting Networking Solution

NOTICE

- The inverter connects to a smart meter or CT to enable output power limit and load monitoring functions.
- Please use SolarGo APP to enable the "Export power limit" function.

The photovoltaic power station generates electricity for self-consumption. When the electrical equipment cannot consume all the generated power, and surplus power would flow back into the grid, the inverter can monitor the grid-connection point power data in real-time via a smart meter and adjust its output power to prevent feeding excess electricity into the grid.

WARNING

1. For single-unit networking, during First-time Installation, there is no need to pay attention to the CT sampling current direction; when replacing or maintaining the CT later, please use the meter/CT auxiliary detection function on the SolarGo APP to allow the inverter to re-adapt to the CT sampling current direction.
2. For multi-unit networking, the CT installation position should be close to the grid connection point, with the correct installation direction. The '-->' in the CT indicates the direction of inverter current pointing to the grid. If reversed, the inverter will trigger an alarm and cannot achieve the output limitation function.
3. The aperture of the CT must be larger than the outer diameter of the AC power

line to ensure that the AC power line can pass through the CT.

4. The CT must be clamped on the L cable, and do not clamp it on the N cable.
5. The CT shipped with the inverter has a sampling range: 90A; ratio: 1000:1; cable length: 5m.
6. GM330:
 - For the CT current ratio specification, please select nA/5A. (nA: CT primary side input current, where n ranges from 200 to 5000, selected by the user based on actual needs. 5A: CT secondary side output current.)
 - The accuracy value of the CT is recommended to be selected as 0.5, 0.5s, 0.2, or 0.2s to ensure that the CT current sampling error is $\leq 1\%$.
 - To ensure the current detection accuracy of the CT, the CT cable length is recommended not to exceed 30m, and the cable's current carrying capacity is recommended to be 6A.
7. Please ensure that the meter wiring and phase sequence are correct. The recommended cross-sectional area for the meter input voltage cable: 1mm^2 (18AWG).
8. For multi-unit networking power limitation, it needs to match Ezlink3000. If needed, please contact after-sales service or a distributor for purchase.
9. The inverter supports parameter settings locally via 4G, WiFi/LAN communication modules, connecting to a mobile phone or WEB interface to set device-related parameters, view device operation information, error information, and promptly understand the system status.
10. When there is only one inverter in the system, you can use 4G Kit-CN-G20 , 4G Kit-CN-G21, WiFi/LAN Kit-20, or WiFi Kit-20 smart dongles.
11. When the system contains multiple inverters for unit networking, the main inverter needs to install an Ezlink3000 smart dongle for networking, and the slave inverters do not need to connect to a smart dongle. The Ezlink3000 version should be V1.6.8 or above.
12. After wiring is completed, set the relevant parameters via the LCD display or SolarGo APP to complete the anti-backflow or output power limitation function.

NOTICE

This electricity meter is primarily used for power control at the grid connection point. The measured power generation and consumption data are for reference only and cannot be used as the basis for electricity billing. Electricity billing must be based on the metering device of the grid company.

Single-Unit Power Limiting Networking Solution Meter Solution (GM1000/GMK110)

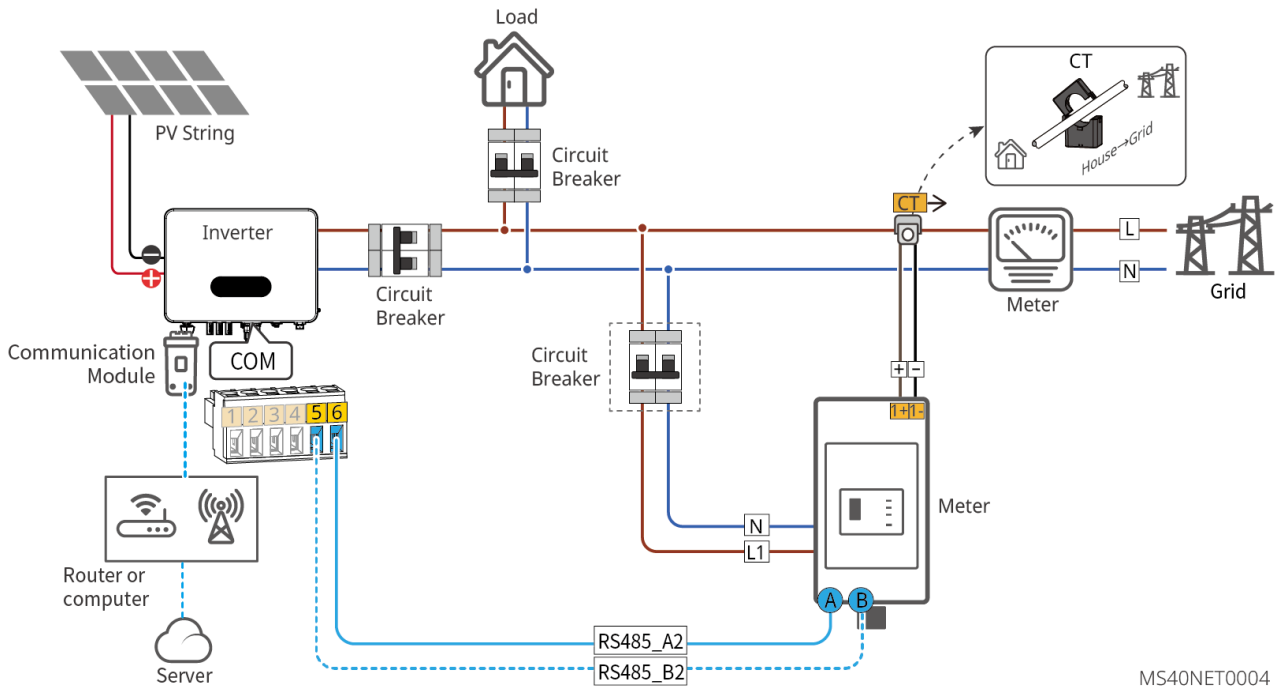

CT Solution

NOTICE

CTs are shipped with the inverter for the Australian region and are optional for other regions. CT ratio: 90A/90mA.

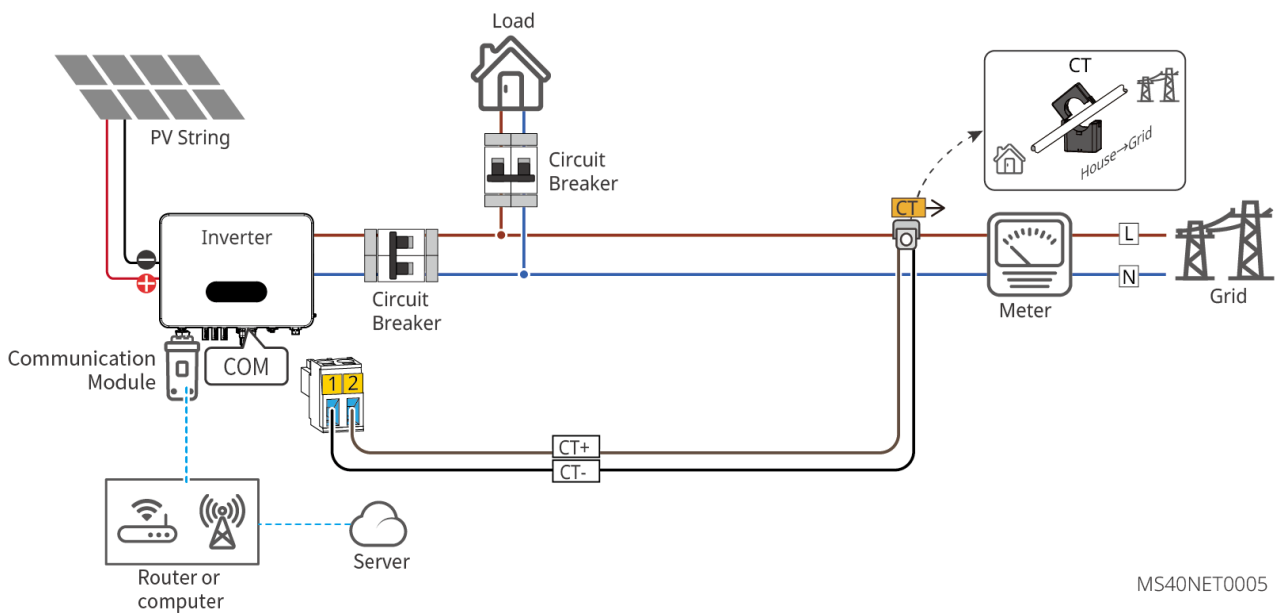

Single-Unit Power Limiting Networking Solution when Connected to a Split-

Phase Grid

NOTICE

Users prepare their own or purchase CT from the manufacturer. CT ratio: 90A/45mA.

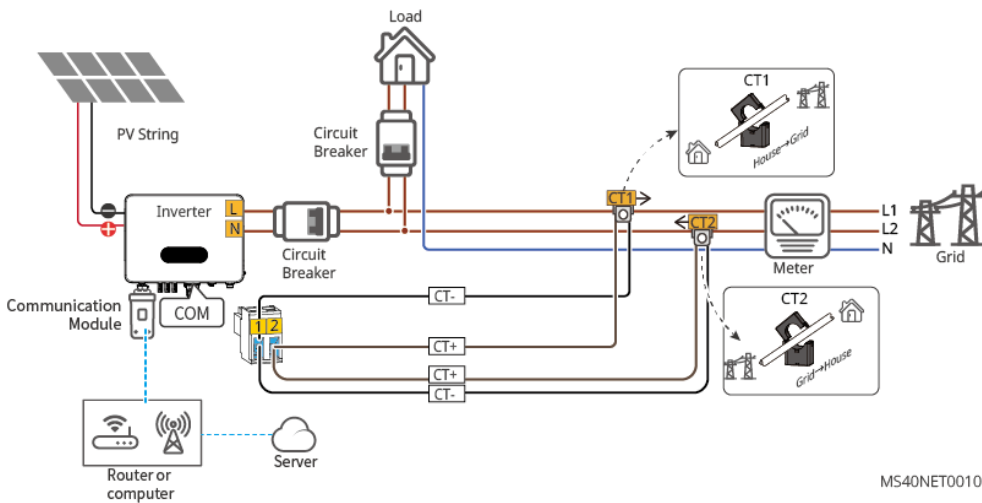

Multi-Unit Power Limiting Networking Solution (GM330+Ezlink3000)

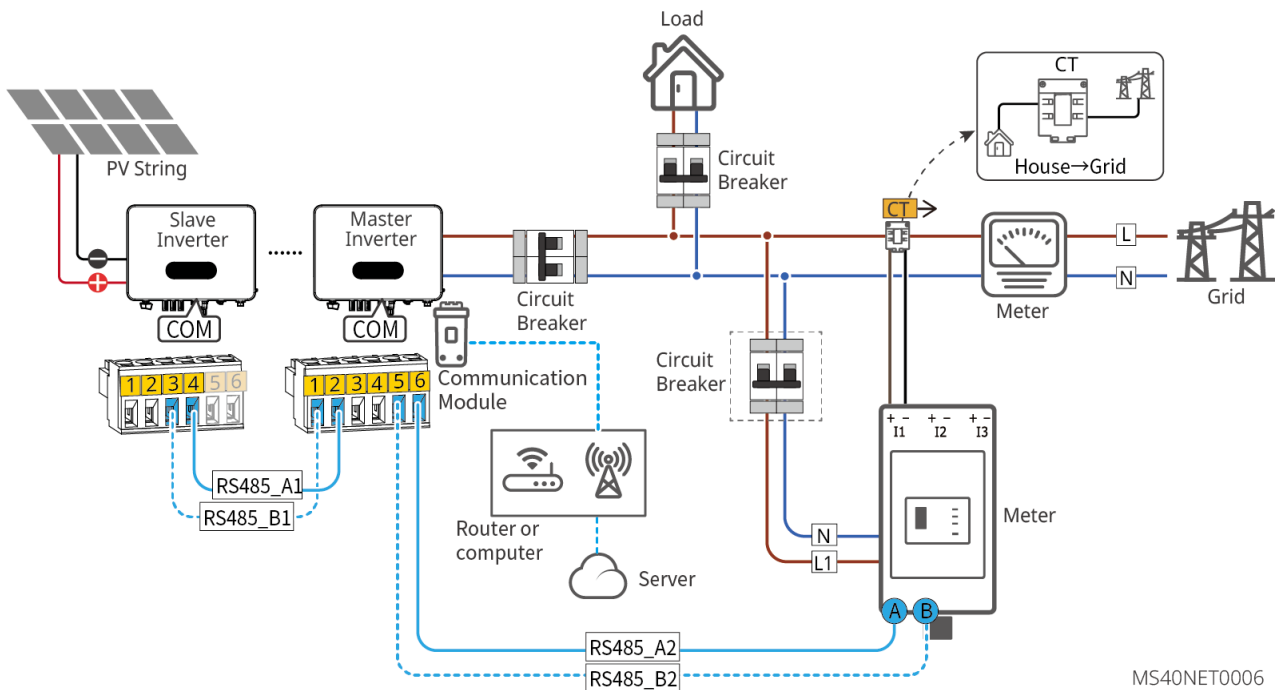

5.5.2 Connecting Communication Cable

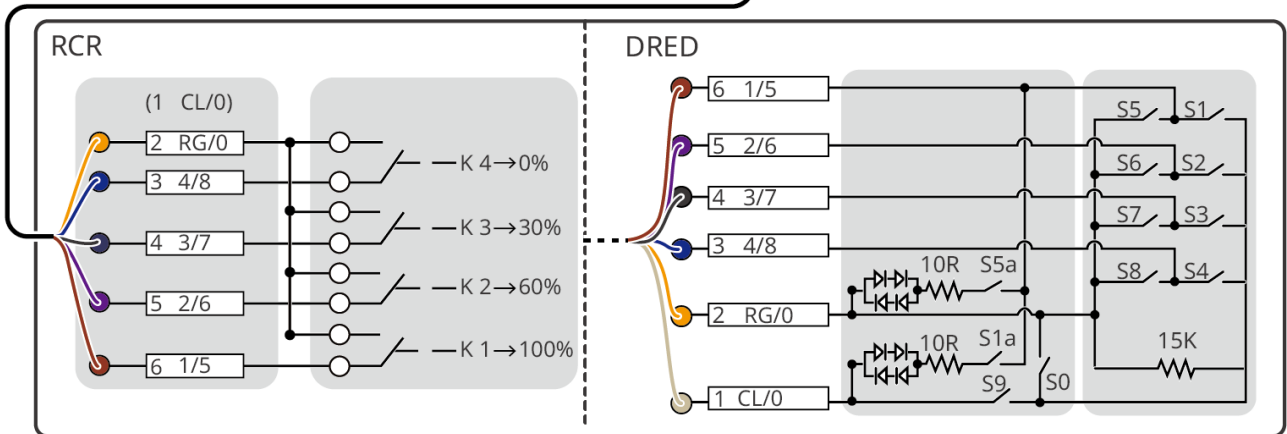
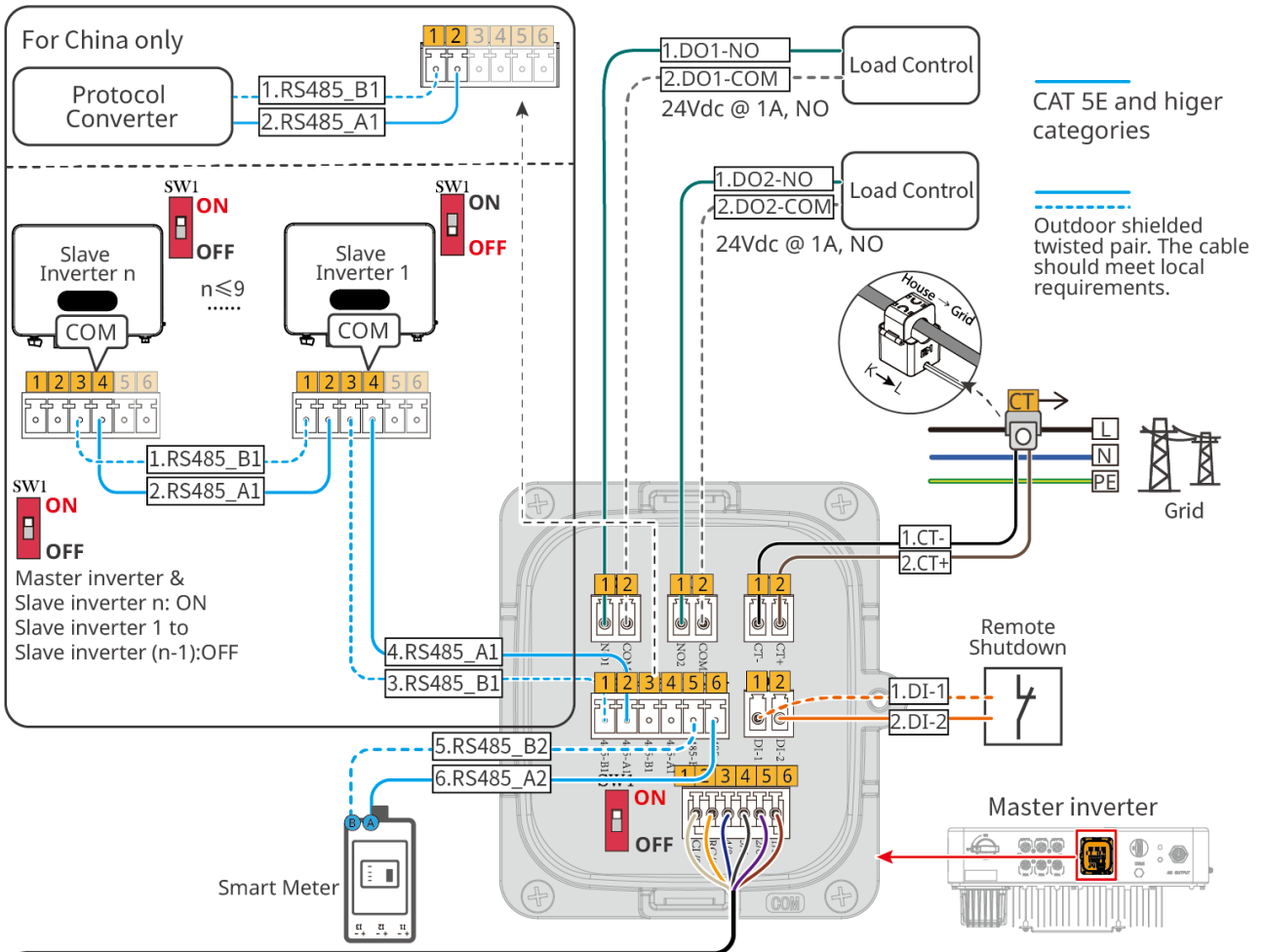

MS40ELC0006

Marking	Function	Description
DO1 DO2	load control (optional)	<ul style="list-style-type: none"> • Supports connection to dry contact signals to achieve functions such as load control. DO contact capacity is 24VDC@1A, NO normally open contacts. • Supports SG Ready heat pump connection, controlling the heat pump through dry contact signals.
CT	CT connection port (CT)	Used for single-unit output power limitation.
RS485	Parallel communication port or protocol converter communication port (RS485-1)	<ul style="list-style-type: none"> • Used for communication between multiple inverters in parallel or connecting to a protocol converter (China only). • The inverter uses the same set of RS485 ports for connecting to the protocol converter and for parallel operation. If a protocol converter is connected, the inverter parallel function cannot be used; in inverter parallel connection scenarios, the protocol converter cannot be connected.
Meter	Meter connection port (RS485-2)	The inverter, paired with a meter, achieves output power limitation function. If matching equipment is needed, contact the inverter manufacturer for purchase.
DI	Remote Shutdown	After the emergency switch sends a shutdown signal, the AC side of the inverter automatically disconnects, stopping grid connection. An external emergency shutdown switch is required.

Marking	Function	Description
DRM/RCR	DRED (Australia) or RCR (Europe) connection port	<ul style="list-style-type: none"> • DRED (Demand Response Enabling Device): Provides a DRED signal control port to meet the grid dispatch requirements of Australia and New Zealand. DRM1-4 functions are reserved, and DRM equipment must be provided by the user. • RCR (Ripple Control Receiver): Provides an RCR signal control port to meet the grid dispatch requirements of regions such as Germany.
SW1	Terminal resistor DIP switch	<p>The inverter is equipped with an RS485 terminal resistor. This terminal resistor DIP switch is enabled by default. "ON" represents enabled, "1" represents disabled.</p> <p>Operation method: Open the outer cover of the communication port, and use an insulated pick to switch the terminal resistor DIP switch to "1" (OFF).</p>

NOTICE

- When connecting communication cables, ensure that the wiring port definitions exactly match the device, and the cable routing path should avoid interference sources, power lines, etc., to prevent affecting signal reception.
- When connecting remote shutdown, CT, dry contact communication cables, use 2PIN communication terminals.
- When connecting R485(electric meter), DRED/RCR communication cables, use 6PIN communication terminals.
- If you need to use DRED, RCR or remote shutdown function, after wiring is completed, please enable this function in the SolarGo APP .
- If the inverter is not connected to DRED, RCR or remote shutdown devices, do not enable this function in the SolarGo APP , otherwise the inverter cannot operate in grid-connected mode.
- For more detailed information on the communication module, please obtain it from the official website.
- USB-RS485 adapter cable is only used for Brazilian models. If needed, please contact after-sales service.
- Communication cable type requirement: RS485 communication cable must meet local standards for outdoor shielded twisted pair.

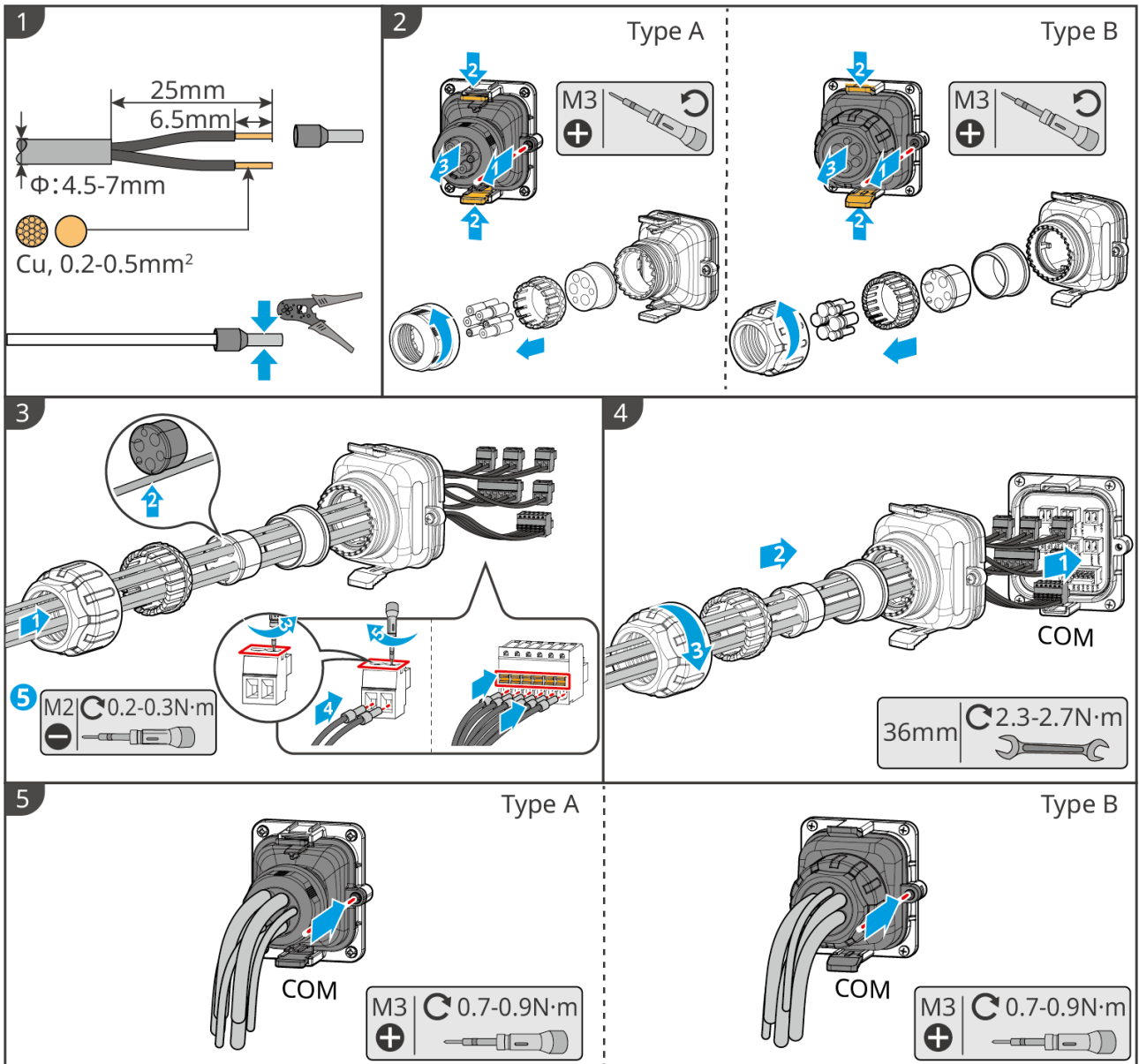

MS40ELC005

China only

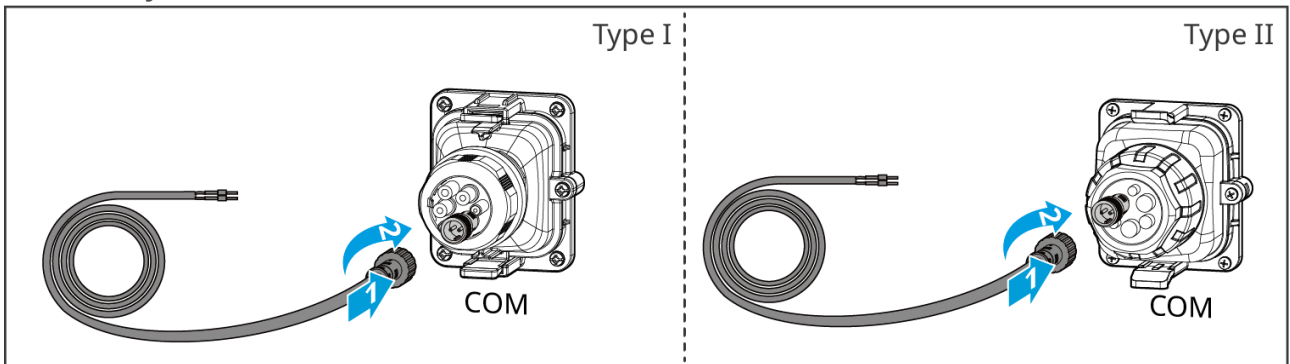

MS40ELC007

6 Equipment Trial Run

6.1 Check Before Power ON

No.	Check Item
1	The equipment is installed securely, the installation location facilitates operation and maintenance, the installation space allows for ventilation and heat dissipation, and the installation environment is clean and tidy.
2	The PE cable, DC cable, AC cable, and communication cable are connected correctly and securely.
3	Cable ties meet cabling requirements, are distributed reasonably, and show no damage.
4	For unused cable entry holes and ports, ensure they are reliably connected using the terminals provided with the accessories and have been sealed.
5	Ensure that used cable entry holes have been sealed.
6	The voltage and frequency at the inverter grid connection point meet grid connection requirements.

6.2 Powering On the Device

1. Close the AC switch between the inverter and the grid.
2. Close the DC switch between the inverter and the PV modules.
3. Close the DC switch of the inverter.

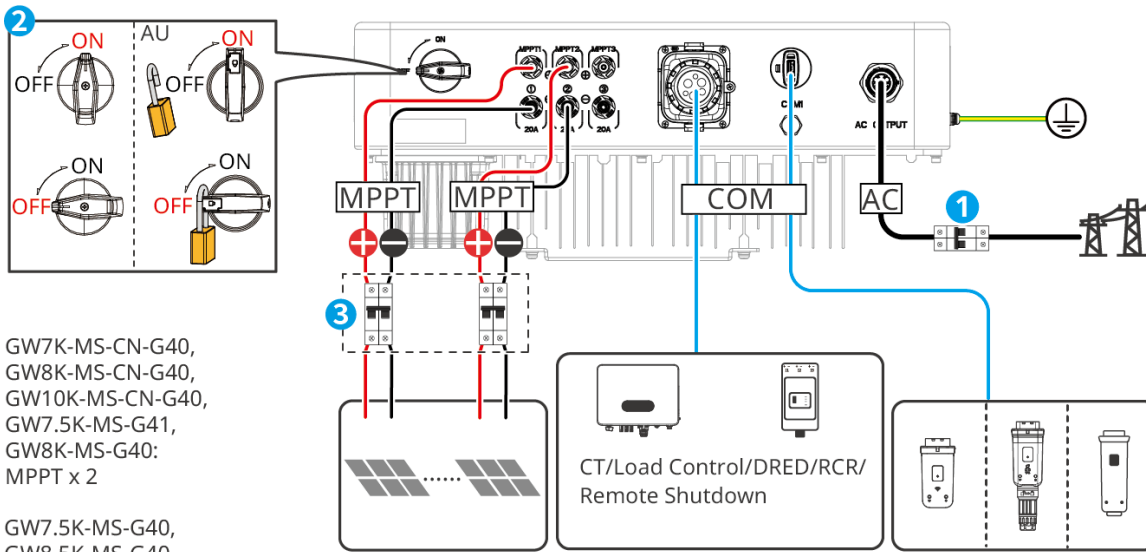

GW7K-MS-CN-G40,
 GW8K-MS-CN-G40,
 GW10K-MS-CN-G40,
 GW7.5K-MS-G41,
 GW8K-MS-G40:
 MPPT x 2

GW7.5K-MS-G40,
 GW8.5K-MS-G40,
 GW9.99K-MS-G40,
 GW10K-MS-G40: MPPT x 3



















Power On : ① → ③ → ②

Power Off : ① → ② → ③

MS40PWR0001

7 System Commissioning

7.1 Indicator Light Instructions

Indicator	Status	Description
 Power		Steady on: Device powered on
		Off: Device not powered
 Run		Steady on: Grid normal, grid connection successful
		Off: Not connected to grid
		Single slow flash: Self-check before grid connection
		Single fast flash: About to connect to grid
 Communi- cation		Steady on: Wireless monitoring normal
		Single flash: Wireless module reset or reconfigured
		Two flashes: Not connected to base station or router
		Four flashes: Not connected to monitoring server
		Flashing: RS485 communication normal
		Off: Wireless module restoring factory settings
 Fault		Steady on: System fault
		Off: No fault

7.2 Setting Inverter Parameters via the Display Screen

NOTICE

- The interface images in this article correspond to inverter firmware version: V1.00.00; communication version: V1.00. The interface is for reference only, subject to the actual display.
- Parameter names, ranges, and default values may be changed or adjusted later, subject to the actual display.
- Inverter power parameters must be set and monitored by professionals to avoid incorrect settings affecting inverter power generation.

Display Screen Button Description

- At any menu level, if no button is pressed for a certain period, the LCD screen will dim, and the interface will automatically return to the initial screen.
- Short press the display screen operation button: Switch menu interfaces or adjust parameter values.
- Long press the display screen operation button: Confirm and save the adjusted parameter value; Enter the next sub-menu level.

Button Operation Example:

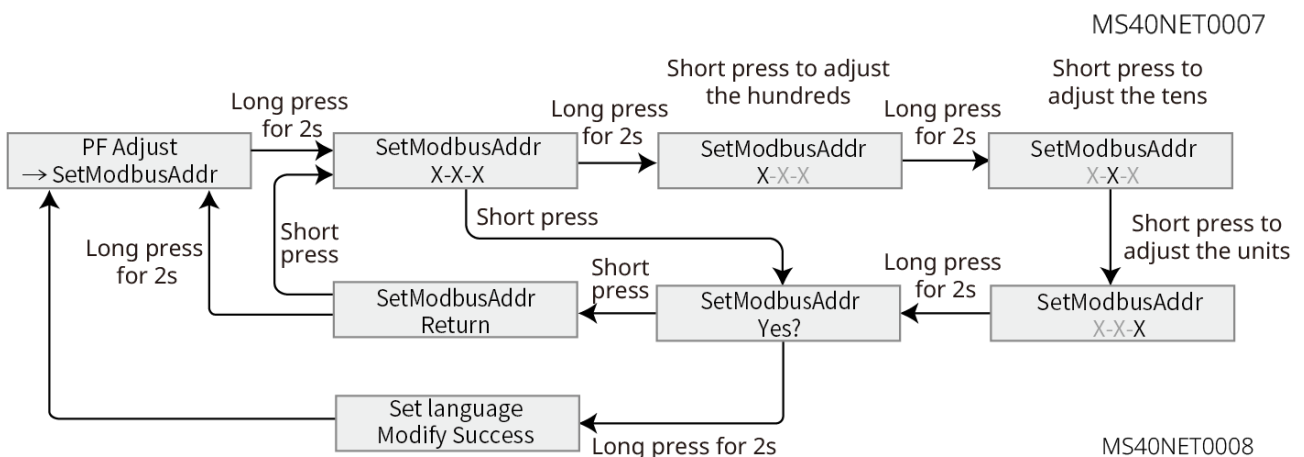
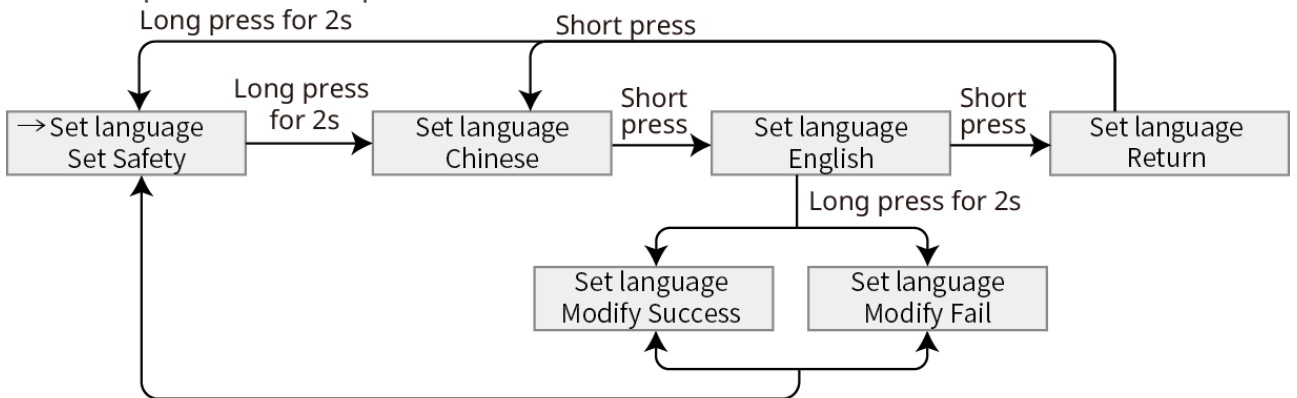

7.2.1 Display Screen Menu Introduction

Introduces the display screen menu structure, allowing you to navigate through various menu levels to view inverter information and set relevant inverter parameters.

First level menu

Second level menu

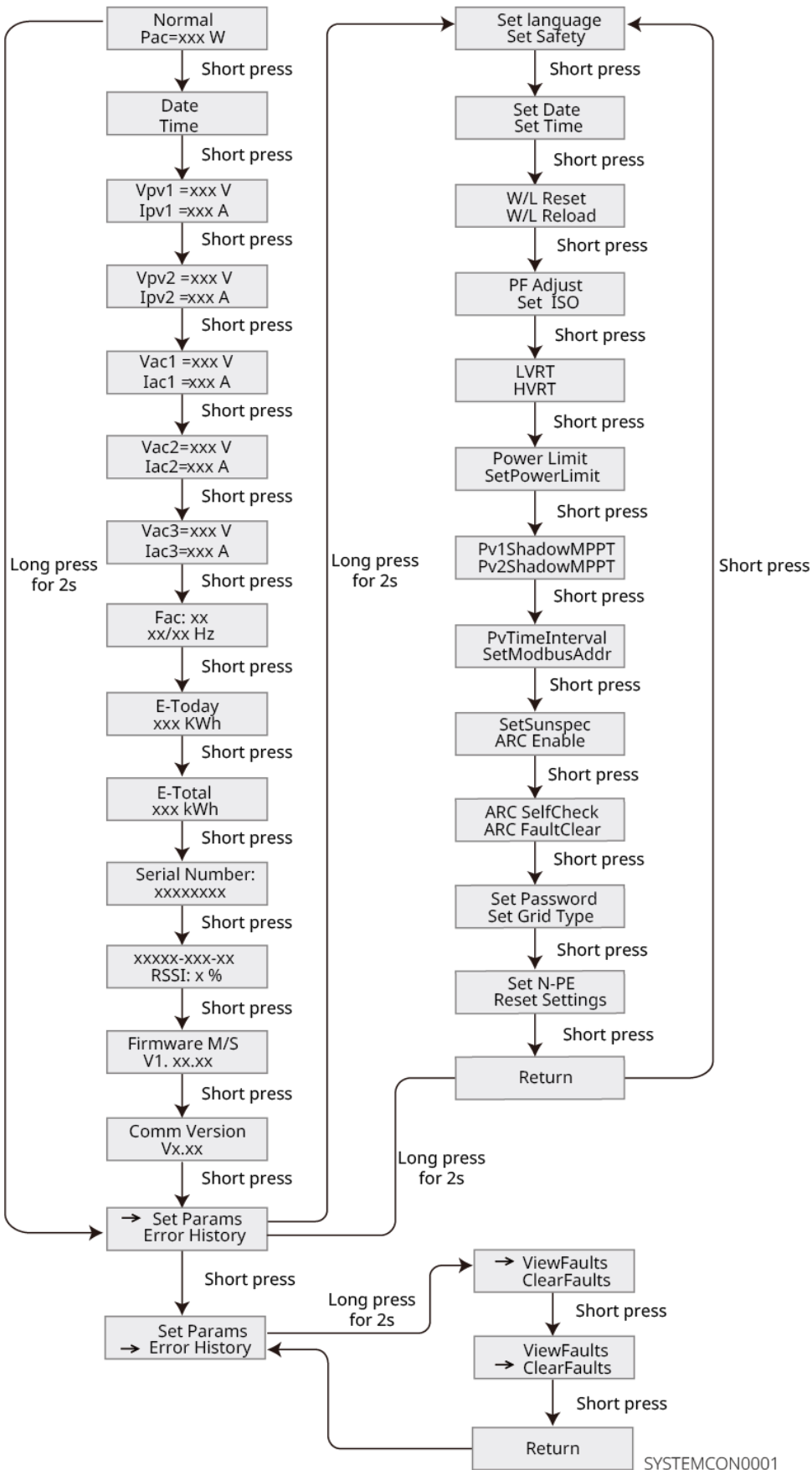

7.3 Setting Inverter Parameters via App

SolarGo APP is a mobile application software that can communicate with inverters via Bluetooth and WiFi. The following are common functions:

1. View the inverter's operating data, software version, alarm information, etc.
2. Set the inverter's grid parameters, communication parameters, etc.
3. Maintain the device.

For detailed functions, please refer to the 'SolarGo APP User Manual'. The user manual can be obtained from the official website or by scanning the QR code below.



SolarGo APP



SolarGo APP User Manual

7.4 Download SEMS+ APP

Mobile Requirements:

- Operating System: Android 6.0 and above, iOS 13.0 and above.
- The device must have a web browser and Internet connectivity.
- The device must support WLAN/Bluetooth functionality.

Download Methods:

Method 1:

Search for SEMS+ in Google Play (Android) or the App Store (iOS) to download and install.

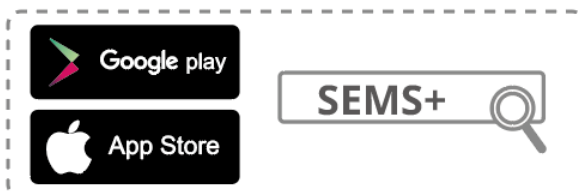

Method 2:

Scan the QR code below to download and install.



8 Maintenance

8.1 Inverter Shutdown

DANGER

- When performing operation and maintenance on the inverter, please power off the inverter. Operating the device while powered on may cause inverter damage or electric shock DANGER.
- After the inverter is powered off, the internal components require some time to discharge. Please wait until the device is completely discharged according to the time requirements on the label.

Step 1: (Optional) Issue a stop grid-connection command to the inverter.

Step 2: Disconnect the AC switch between the inverter and the grid.

Step 3: Disconnect the DC switch of the inverter.

Step 4: (Optional) Disconnect the switch between the inverter and the photovoltaic modules.

8.2 Removing the Inverter

WARNING

- Ensure the inverter is powered off.
- Wear personal protective equipment when operating the inverter.

Step 1: Disconnect all electrical connections of the inverter, including: DC cables, AC cables, Communication cable, smart dongle, PE cable.

Step 2: Remove the inverter from the mounting plate.

Step 3: Remove the mounting plate.

Step 4: Store the inverter properly. If the inverter will be put into use later, ensure the storage conditions meet the requirements.

8.3 Inverter Scrapping

When an inverter can no longer be used and requires scrapping, it must be disposed of in accordance with the electrical waste disposal regulations of the country/region where the inverter is located. The inverter must not be treated as general household waste.

8.4 Inverter Fault

8.4.1 Troubleshooting (Fault Codes F01-F40)

Fault Code	Fault Name	Fault Cause	Recommended Troubleshooting
F01	Grid Power Outage	<ol style="list-style-type: none"> 1. Grid power outage. 2. AC line or AC switch is disconnected. 	<ol style="list-style-type: none"> 1. The alarm disappears automatically after grid power is restored. 2. Check if the AC line or AC switch is disconnected.
F02	Grid Overvoltage Protection	Grid voltage is higher than the allowable range, or the duration of high voltage exceeds the high voltage ride-through setting.	<ol style="list-style-type: none"> 1. If it occurs occasionally, it may be a temporary grid abnormality. The inverter will resume normal operation after detecting the grid is normal, requiring no manual intervention. 2. If it occurs frequently, check if the grid voltage is within the allowable range. If not, contact the local power operator. If it is, you also need to modify the grid overvoltage protection point after obtaining consent from the local power operator. 3. If it cannot be restored for a long time, check if the AC side circuit breaker and output cables are connected properly.

Fault Code	Fault Name	Fault Cause	Recommended Troubleshooting
F03	Grid Undervoltage Protection	Grid voltage is lower than the allowable range, or the duration of low voltage exceeds the low voltage ride-through setting.	<ol style="list-style-type: none"> 1. If it occurs occasionally, it may be a temporary grid abnormality. The inverter will resume normal operation after detecting the grid is normal, requiring no manual intervention. 2. If it occurs frequently, check if the grid voltage is within the allowable range. If not, contact the local power operator. If it is, you also need to modify the grid undervoltage protection point after obtaining consent from the local power operator. 3. If it cannot be restored for a long time, check if the AC side circuit breaker and output cables are connected properly.

Fault Code	Fault Name	Fault Cause	Recommended Troubleshooting
F04	Grid Rapid Overvoltage Protection	Abnormal grid voltage detection or extremely high voltage triggers the fault.	<p>1. If it occurs occasionally, it may be a temporary grid abnormality. The inverter will resume normal operation after detecting the grid is normal, requiring no manual intervention.</p> <p>2. If it occurs frequently, check if the grid voltage is within the allowable range. If not, contact the local power operator. If it is, you also need to modify the grid undervoltage protection point after obtaining consent from the local power operator.</p> <p>3. If it cannot be restored for a long time, check if the AC side circuit breaker and output cables are connected properly.</p>
F05	10min Overvoltage Protection	The sliding average of grid voltage within 10min exceeds the range specified by safety regulations.	Check if the grid voltage has been operating at a high level for a long time. If it occurs frequently, check if the grid frequency is within the allowable range. If not, contact the local power operator. If it is, you also need to modify the grid 10min overvoltage protection point after obtaining consent from the local power operator.

Fault Code	Fault Name	Fault Cause	Recommended Troubleshooting
F06	Grid Overfrequency	Grid abnormality: The actual grid frequency is higher than the local grid standard requirement.	<p>1. If it occurs occasionally, it may be a temporary grid abnormality. The inverter will resume normal operation after detecting the grid is normal, requiring no manual intervention.</p> <p>2. If it occurs frequently, check if the grid frequency is within the allowable range. If not, contact the local power operator. If it is, you also need to modify the grid overfrequency protection point after obtaining consent from the local power operator.</p>
F07	Grid Underfrequency	Grid abnormality: The actual grid frequency is lower than the local grid standard requirement.	<p>1. If it occurs occasionally, it may be a temporary grid abnormality. The inverter will resume normal operation after detecting the grid is normal, requiring no manual intervention.</p> <p>2. If it occurs frequently, check if the grid frequency is within the allowable range. If not, contact the local power operator. If it is, you also need to modify the grid overfrequency protection point after obtaining consent from the local power operator.</p>

Fault Code	Fault Name	Fault Cause	Recommended Troubleshooting
F08	Grid Frequency Instability	Grid abnormality: The rate of change of the actual grid frequency does not comply with the local grid standard.	<p>1. If it occurs occasionally, it may be a temporary grid abnormality. The inverter will resume normal operation after detecting the grid is normal, requiring no manual intervention.</p> <p>2. If it occurs frequently, check if the grid frequency is within the allowable range. If not, contact the local power operator.</p>
F09	Anti-islanding Protection	The grid has been disconnected, but grid voltage is maintained due to the presence of loads. Grid connection is stopped according to safety regulation protection requirements.	<p>1. If it occurs occasionally, it may be a temporary grid abnormality. The inverter will resume normal operation after detecting the grid is normal, requiring no manual intervention.</p> <p>2. If it occurs frequently, check if the grid frequency is within the allowable range. If not, contact the local power operator.</p>
F10	LVRT Undervoltage	Grid abnormality: The duration of abnormal grid voltage exceeds the time specified by the high/low voltage ride-through regulations.	<p>1. If it occurs occasionally, it may be a temporary grid abnormality. The inverter will resume normal operation after detecting the grid is normal, requiring no manual intervention.</p> <p>2. If it occurs frequently, check if the grid voltage and frequency are within the allowable range and stable. If not, contact the local power operator.</p>

Fault Code	Fault Name	Fault Cause	Recommended Troubleshooting
F11	HVRT Overvoltage	Grid abnormality: The duration of abnormal grid voltage exceeds the time specified by the high/low voltage ride-through regulations.	<p>1. If it occurs occasionally, it may be a temporary grid abnormality. The inverter will resume normal operation after detecting the grid is normal, requiring no manual intervention.</p> <p>2. If it occurs frequently, check if the grid voltage and frequency are within the allowable range and stable. If not, contact the local power operator.</p>
F12	30mA GFCI Protection	The insulation resistance to ground of the input becomes low during inverter operation.	<p>1. If it occurs occasionally, it may be caused by temporary external line abnormalities. It will resume normal operation after the fault is cleared, requiring no manual intervention.</p> <p>2. If it occurs frequently or cannot be restored for a long time, check if the PV string's impedance to ground is too low.</p>
F13	60mA GFCI Protection	The insulation resistance to ground of the input becomes low during inverter operation.	<p>1. If it occurs occasionally, it may be caused by temporary external line abnormalities. It will resume normal operation after the fault is cleared, requiring no manual intervention.</p> <p>2. If it occurs frequently or cannot be restored for a long time, check if the PV string's impedance to ground is too low.</p>

Fault Code	Fault Name	Fault Cause	Recommended Troubleshooting
F14	150mA GFCI Protection	The insulation resistance to ground of the input becomes low during inverter operation.	<p>1. If it occurs occasionally, it may be caused by temporary external line abnormalities. It will resume normal operation after the fault is cleared, requiring no manual intervention.</p> <p>2. If it occurs frequently or cannot be restored for a long time, check if the PV string's impedance to ground is too low.</p>
F15	GFCI Gradual Change Protection	The insulation resistance to ground of the input becomes low during inverter operation.	<p>1. If it occurs occasionally, it may be caused by temporary external line abnormalities. It will resume normal operation after the fault is cleared, requiring no manual intervention.</p> <p>2. If it occurs frequently or cannot be restored for a long time, check if the PV string's impedance to ground is too low.</p>
F16	DCI Level 1 Protection	The DC component of the inverter output current is higher than the range allowed by safety regulations or the machine default.	<p>1. If it is caused by an external fault, the inverter will automatically resume normal operation after the fault disappears, requiring no manual intervention.</p> <p>2. If this alarm occurs frequently, affecting the normal power generation of the power station, contact the dealer or after-sales service center.</p>

Fault Code	Fault Name	Fault Cause	Recommended Troubleshooting
F17	DCI Level 2 Protection	The DC component of the inverter output current is higher than the range allowed by safety regulations or the machine default.	<p>1. If it is caused by an external fault, the inverter will automatically resume normal operation after the fault disappears, requiring no manual intervention.</p> <p>2. If this alarm occurs frequently, affecting the normal power generation of the power station, contact the dealer or after-sales service center.</p>

Fault Code	Fault Name	Fault Cause	Recommended Troubleshooting
F18	Low Insulation Resistance	<ol style="list-style-type: none"> 1. PV string short circuit to protective earth. 2. The PV string is installed in a long-term humid environment and the line has poor insulation to ground. 3. Low insulation impedance to ground of the battery port line. 	<ol style="list-style-type: none"> 1. Check the impedance of the PV string/battery port to the protective earth. A value greater than 80kΩ is normal. If the checked value is less than 80kΩ, locate and rectify the short circuit point. 2. Check if the inverter's protective earth wire is correctly connected. 3. If it is confirmed that the impedance is indeed below the default value in rainy weather, reset the inverter's "Insulation Resistance Protection Point" via the App. <p>For inverters in the Australian and New Zealand markets, when an insulation resistance fault occurs, the alarm can also be indicated in the following ways:</p> <ol style="list-style-type: none"> 1. The inverter is equipped with a buzzer. When a fault occurs, the buzzer sounds continuously for 1 minute; if the fault is not resolved, the buzzer sounds again every 30 minutes. 2. If the inverter is added to the monitoring platform and the alarm notification method is set, the alarm information can be sent to the customer via email.

Fault Code	Fault Name	Fault Cause	Recommended Troubleshooting
F19	Grounding Abnormal	1. The inverter's protective earth wire is not connected. 2. When the PV string output is grounded, the inverter output side is not connected to an isolation transformer.	1. Please confirm if the inverter's protective earth wire is not connected properly. 2. In scenarios where the PV string output is grounded, please confirm if an isolation transformer is connected to the inverter output side.
F20	Hard Reverse Power Protection	Load abnormal fluctuation	1. If it is caused by an external fault, the inverter will automatically resume normal operation after the fault disappears, requiring no manual intervention. 2. If this alarm occurs frequently, affecting the normal power generation of the power station, contact the dealer or after-sales service center.

Fault Code	Fault Name	Fault Cause	Recommended Troubleshooting
F21	Internal Comm Loss	Slave DSP1 communication timeout - Master DSP, Slave DSP2 communication timeout - Master DSP, Slave DSP2 communication timeout - Slave DSP1, Master DSP communication timeout - Slave DSP1, Master DSP communication timeout - Slave DSP2 or Slave DSP1 communication timeout - Slave DSP2: 1. Chip not powered on 2. Chip program version error	Disconnect the AC output side switch and DC input side switch, wait 5 minutes, then close the AC output side switch and DC input side switch. If the fault persists, contact the dealer or after-sales service center.

Fault Code	Fault Name	Fault Cause	Recommended Troubleshooting
		Master DSP can module error, Slave DSP1 can module error or Slave DSP2 can module error: 1. Frame format error 2. Parity check error 3. can bus offline 4. Hardware CRC check error 5. Control bit is receive (send) when sending (receiving) 6. Transmission to a disallowed unit	
F22	Generator Waveform Detection Fault	1. This fault will be displayed continuously when the generator is not connected; 2. When the generator is operating, failure to meet generator safety regulations will trigger this fault.	1. Ignore this fault when the generator is not connected; 2. When this fault appears during a generator fault, it is normal. Wait for a period after the generator recovers, and the fault will clear automatically; 3. This fault does not affect the normal operation of off-grid mode. 4. When both the generator and grid are connected and meet safety requirements, the grid has priority for grid connection, and the system will operate in grid-connected state.
F23	Generator Abnormal Connection		
F24	Generator Voltage Low		
F25	Generator Voltage High		
F26	Generator Frequency Low		
F27	Generator Frequency High		

Fault Code	Fault Name	Fault Cause	Recommended Troubleshooting
F28	Parallel Unit I/O Self-check Abnormal	Parallel communication cable is not securely connected or the parallel IO chip is damaged	Check if the parallel communication cable is securely connected, then check if the IO chip is damaged. If so, replace the IO chip.
F29	Paralell Grid Line Reversed	Grid lines of some units are reversed with others	Reconnect the grid lines.
F30	AC HCT check Abnormal	AC sensor has sampling abnormality	Disconnect the AC output side switch and DC input side switch, wait 5 minutes, then close the AC output side switch and DC input side switch. If the fault persists, contact the dealer or after-sales service center.
F31	GFCI HCT Check Abnormal	Leakage current sensor has sampling abnormality	Disconnect the AC output side switch and DC input side switch, wait 5 minutes, then close the AC output side switch and DC input side switch. If the fault persists, contact the dealer or after-sales service center.
F32	Inverter Internal Failure	Inverter has a fault	Disconnect the AC output side switch and DC input side switch, wait 5 minutes, then close the AC output side switch and DC input side switch. If the fault persists, contact the dealer or after-sales service center.
F33	Flash Read/Write Error	Possible causes: flash content changed; flash lifespan exhausted;	1. Upgrade to the latest program version. 2. Contact the dealer or after-sales service center.

Fault Code	Fault Name	Fault Cause	Recommended Troubleshooting
F34	AFCI Check Failure	During the arc fault self-check, the arc fault module did not detect an arc fault as expected.	Disconnect the AC output side switch and DC input side switch, wait 5 minutes, then close the AC output side switch and DC input side switch. If the fault persists, contact the dealer or after-sales service center.
F35	Cabinet Overtemperature	Cabinet temperature is too high, possible causes: 1. Inverter installation location is not ventilated. 2. Ambient temperature is too high. 3. Internal fan operation is abnormal.	1. Check if the ventilation at the inverter installation location is good, and if the ambient temperature exceeds the maximum allowable ambient temperature range. 2. If ventilation is poor or ambient temperature is too high, improve its ventilation and heat dissipation conditions. 3. If both ventilation and ambient temperature are normal, contact the dealer or after-sales service center.

Fault Code	Fault Name	Fault Cause	Recommended Troubleshooting
F36	Bus Overvoltage	BUS overvoltage, possible causes: 1. PV voltage too high; 2. Inverter BUS voltage sampling abnormal; 3. The isolation effect of the dual-split transformer behind the inverter is poor, causing mutual influence when two inverters are connected in parallel, with one inverter reporting DC overvoltage when grid-connected;	Disconnect the AC output side switch and DC input side switch, wait 5 minutes, then close the AC output side switch and DC input side switch. If the fault persists, contact the dealer or after-sales service center.

Fault Code	Fault Name	Fault Cause	Recommended Troubleshooting
F37	PV Input Overvoltage	PV input voltage too high, possible cause: PV array configuration error, too many PV panels connected in series in a string, causing the string's open-circuit voltage to be higher than the inverter's maximum operating voltage.	Check the series configuration of the corresponding PV array string to ensure the string's open-circuit voltage does not exceed the inverter's maximum operating voltage. After the PV array is correctly configured, the inverter alarm will disappear automatically.
F38	PV Sustained Hardware Overcurrent	1. Component configuration不合理 2. Hardware damage	Disconnect the AC output side switch and DC input side switch, wait 5 minutes, then close the AC output side switch and DC input side switch. If the fault persists, contact the dealer or after-sales service center.
F39	PV Sustained Software Overcurrent	1. Component configuration不合理 2. Hardware damage	Disconnect the AC output side switch and DC input side switch, wait 5 minutes, then close the AC output side switch and DC input side switch. If the fault persists, contact the dealer or after-sales service center.

Fault Code	Fault Name	Fault Cause	Recommended Troubleshooting
F40, F98	String Reverse Polarity (String 1-n) n: Determined based on the actual number of inverter strings.	PV string reverse polarity	Check if the string is reverse connected.

8.4.2 Troubleshooting (Fault Codes F41-F80)

Fault Code	Fault Name	Fault Cause	Recommended Action
F41	Generator Port Overload	<ol style="list-style-type: none"> 1. Off-grid side output exceeds the specifications. 2. Short circuit on the off-grid side. 3. Off-grid terminal voltage is too low. 4. When used as a large load port, the large load exceeds the specifications. 	Confirm the off-grid side output voltage, current, power and other data to identify the cause of the problem.

Fault Code	Fault Name	Fault Cause	Recommended Action
F42	DC Arcing Failure (String 1-n) n: Determined by the actual number of inverter strings.	1. DC side connection terminals are loose; 2. DC side connection terminals have poor contact; 3. DC cable core is damaged causing poor contact.	1. After the unit reconnects to the grid, check if the voltage and current of each circuit abnormally decrease or become zero; 2. Check if the DC side terminals are securely connected.
F43	Grid Waveform Abnormal	Utility grid abnormality: Abnormal grid voltage detection triggers the fault.	1. If it occurs occasionally, it may be due to a temporary grid abnormality. The inverter will resume normal operation after detecting a normal grid, requiring no manual intervention. 2. If it occurs frequently, please check if the grid voltage and frequency are within the allowable range and stable. If not, please contact the local power operator.
F44	Grid Phase Loss	Utility grid abnormality: Single-phase voltage dip in the grid.	1. If it occurs occasionally, it may be due to a temporary grid abnormality. The inverter will resume normal operation after detecting a normal grid, requiring no manual intervention. 2. If it occurs frequently, please check if the grid voltage and frequency are within the allowable range and stable. If not, please contact the local power operator.

Fault Code	Fault Name	Fault Cause	Recommended Action
F45	Grid Voltage Imbalance	Excessive difference in grid phase voltages.	<p>1. If it occurs occasionally, it may be due to a temporary grid abnormality. The inverter will resume normal operation after detecting a normal grid, requiring no manual intervention.</p> <p>2. If it occurs frequently, please check if the grid voltage and frequency are within the allowable range and stable. If not, please contact the local power operator.</p>
F46	Grid Phase Sequence Failure	Inverter and grid wiring abnormality: Wiring is not in positive sequence.	<p>1. Check if the inverter and grid wiring are in positive sequence. The fault will automatically disappear after correct wiring (e.g., swapping any two live wires).</p> <p>2. If the fault persists despite correct wiring, please contact the dealer or after-sales service center.</p>
F47	Grid Rapid Shutdown Protection	Quickly shuts down output after detecting a grid power outage condition.	The fault automatically disappears after grid power supply is restored.
F48	Grid Neutral Wire Loss (Split-phase grid)	Loss of neutral wire in a split-phase grid.	<p>1. The alarm automatically disappears after grid power supply is restored.</p> <p>2. Check if the AC wiring or AC switch is disconnected.</p>
F49	L-PE Short Circuit	Output phase line has low impedance or short circuit to PE.	Measure the impedance between the output phase line and PE, identify the location of low impedance and repair it.

Fault Code	Fault Name	Fault Cause	Recommended Action
F50	DCV Level 1 Protection	Abnormal load fluctuation	1. If it is caused by an external fault, the inverter will automatically resume normal operation after the fault disappears, requiring no manual intervention. 2. If this alarm occurs frequently, affecting normal power generation of the plant, please contact the dealer or after-sales service center.
F51	DCV Level 2 Protection	Abnormal load fluctuation	
F52	GFCI Multiple Fault Shutdown	North American safety regulations require no automatic recovery after multiple faults; manual recovery or waiting 24h is required.	Please check if the PV string's impedance to ground is too low.
F53	DC Arcing (AFCI) Multiple Fault Shutdown	North American safety regulations require no automatic recovery after multiple faults; manual recovery or waiting 24h is required.	1. After the unit reconnects to the grid, check if the voltage and current of each circuit abnormally decrease or become zero; 2. Check if the DC side terminals are securely connected.
F54	External Communication Link Broken	Inverter external device communication lost, possibly due to peripheral power issue, communication protocol mismatch, not configured for the corresponding peripheral, etc.	Determine based on the actual model and detection enable bits. Peripherals not supported by certain models will not be detected.

Fault Code	Fault Name	Fault Cause	Recommended Action
F55	Back-up Port Overload Fault	Prevents the inverter from continuously outputting overload.	Turn off some off-grid loads to reduce the inverter's off-grid output power.
F56	Back-up Port Overvoltage Fault	Prevents inverter output overvoltage from damaging loads.	1. If it occurs occasionally, it may be caused by load switching and requires no manual intervention. 2. If it occurs frequently, please contact the dealer or after-sales service center.
F57	External Box Fault	Waiting too long for Box relay switching during grid-to-off-grid transition.	1. Check if the Box is working normally; 2. Check if the Box communication wiring is correct;
F58	CT Loss Fault	CT connection wire disconnected (Japanese safety regulation requirement).	Check if the CT wiring is correct;
F59	Parallel CAN Communication Abnormal	Parallel communication cable not securely connected or some units are offline.	Check if all units are powered on and if the parallel communication cables are securely connected.
F60	Parallel Backup Wiring Reversed	Backup wiring of some units is reversed with others.	Reconnect the backup wiring.
F61	Inverter Soft Start Failure	Inverter soft start failure during off-grid cold start.	Check if the inverter module is damaged.

Fault Code	Fault Name	Fault Cause	Recommended Action
F62	AC HCT Failure	HCT sensor abnormality exists.	Disconnect the AC output side switch and DC input side switch, wait 5 minutes, then close the AC output side switch and DC input side switch. If the fault persists, please contact the dealer or after-sales service center.
F63	GFCI HCT Failure	Leakage current sensor abnormality exists.	Disconnect the AC output side switch and DC input side switch, wait 5 minutes, then close the AC output side switch and DC input side switch. If the fault persists, please contact the dealer or after-sales service center.
F64	Inverter Internal Failure	Inverter fault exists.	Disconnect the AC output side switch and DC input side switch, wait 5 minutes, then close the AC output side switch and DC input side switch. If the fault persists, please contact the dealer or after-sales service center.
F65	AC Terminal Overtemperature	AC terminal temperature is too high. Possible causes: 1. Inverter installation location lacks ventilation. 2. Ambient temperature is too high. 3. Internal fan operation is abnormal.	1. Check if the ventilation at the inverter installation location is adequate and if the ambient temperature exceeds the maximum allowable range. 2. If ventilation is poor or ambient temperature is too high, please improve its ventilation and heat dissipation conditions. 3. If both ventilation and ambient temperature are normal, please contact the dealer or after-sales service center.

Fault Code	Fault Name	Fault Cause	Recommended Action
F66	INV Module Overtemperature	<p>Inverter module temperature is too high. Possible causes:</p> <ol style="list-style-type: none"> 1. Inverter installation location lacks ventilation. 2. Ambient temperature is too high. 3. Internal fan operation is abnormal. 	<ol style="list-style-type: none"> 1. Check if the ventilation at the inverter installation location is adequate and if the ambient temperature exceeds the maximum allowable range. 2. If ventilation is poor or ambient temperature is too high, please improve its ventilation and heat dissipation conditions. 3. If both ventilation and ambient temperature are normal, please contact the dealer or after-sales service center.
F67	Boost Module Overtemperature	<p>Boost module temperature is too high. Possible causes:</p> <ol style="list-style-type: none"> 1. Inverter installation location lacks ventilation. 2. Ambient temperature is too high. 3. Internal fan operation is abnormal. 	<ol style="list-style-type: none"> 1. Check if the ventilation at the inverter installation location is adequate and if the ambient temperature exceeds the maximum allowable range. 2. If ventilation is poor or ambient temperature is too high, please improve its ventilation and heat dissipation conditions. 3. If both ventilation and ambient temperature are normal, please contact the dealer or after-sales service center.

Fault Code	Fault Name	Fault Cause	Recommended Action
F68	AC Capacitor Overtemperature	Output filter capacitor temperature is too high. Possible causes: 1. Inverter installation location lacks ventilation. 2. Ambient temperature is too high. 3. Internal fan operation is abnormal.	1. Check if the ventilation at the inverter installation location is adequate and if the ambient temperature exceeds the maximum allowable range. 2. If ventilation is poor or ambient temperature is too high, please improve its ventilation and heat dissipation conditions. 3. If both ventilation and ambient temperature are normal, please contact the dealer or after-sales service center.
F69	PV IGBT Short Circuit Fault	Possible causes: 1. IGBT short circuit 2. Inverter sampling circuit abnormality	Disconnect the AC output side switch and DC input side switch, wait 5 minutes, then close the AC output side switch and DC input side switch. If the fault persists, please contact the dealer or after-sales service center.
F70	PV IGBT Open Circuit Fault	1. Software issue causing no PWM generation: 2. Drive circuit abnormality: 3. IGBT open circuit	
F71	NTC Abnormal	NTC temperature sensor abnormality.	Disconnect the AC output side switch and DC input side switch, wait 5 minutes, then close the AC output side switch and DC input side switch. If the fault persists, please contact the dealer or after-sales service center.

Fault Code	Fault Name	Fault Cause	Recommended Action
F72	PWM Abnormal	Abnormal PWM waveform detected.	Disconnect the AC output side switch and DC input side switch, wait 5 minutes, then close the AC output side switch and DC input side switch. If the fault persists, please contact the dealer or after-sales service center.
F73	CPU Interrupt Abnormal	CPU interrupt abnormality detected.	Disconnect the AC output side switch and DC input side switch, wait 5 minutes, then close the AC output side switch and DC input side switch. If the fault persists, please contact the dealer or after-sales service center.
F74	Microelectronics Fault	Functional safety detection detected an abnormality.	Disconnect the AC output side switch and DC input side switch, wait 5 minutes, then close the AC output side switch and DC input side switch. If the fault persists, please contact the dealer or after-sales service center.
F75	PV HCT Fault	Boost current sensor abnormality.	Disconnect the AC output side switch and DC input side switch, wait 5 minutes, then close the AC output side switch and DC input side switch. If the fault persists, please contact the dealer or after-sales service center.
F76	1.5V Reference Abnormal	Reference circuit fault.	Disconnect the AC output side switch and DC input side switch, wait 5 minutes, then close the AC output side switch and DC input side switch. If the fault persists, please contact the dealer or after-sales service center.
F77	0.3V Reference Abnormal	Reference circuit fault.	

Fault Code	Fault Name	Fault Cause	Recommended Action
F78	CPLD Version Recognition Error	CPLD version recognition error.	Disconnect the AC output side switch and DC input side switch, wait 5 minutes, then close the AC output side switch and DC input side switch. If the fault persists, please contact the dealer or after-sales service center.
F79	CPLD Communication Fault	CPLD and DSP communication content error or timeout.	Disconnect the AC output side switch and DC input side switch, wait 5 minutes, then close the AC output side switch and DC input side switch. If the fault persists, please contact the dealer or after-sales service center.
F80	Model Identification Fault	Fault related to model identification error.	Disconnect the AC output side switch and DC input side switch, wait 5 minutes, then close the AC output side switch and DC input side switch. If the fault persists, please contact the dealer or after-sales service center.

8.4.3 Troubleshooting (Fault Codes F81-F121)

Fault Code	Fault Name	Possible Cause	Recommended Action
F81	P-Bus Overvoltage		Disconnect the AC output side switch and the DC input side switch, wait for 5 minutes, then close the AC output side switch and the DC input side switch. If the fault persists, contact the dealer or after-sales service center.

Fault Code	Fault Name	Possible Cause	Recommended Action
F82	N-Bus Overvoltage	BUS overvoltage, possible causes: 1. PV voltage is too high; 2. Inverter BUS voltage sampling is abnormal; 3. Poor isolation of the dual-split transformer at the inverter's rear end causes mutual interference when two inverters are grid-connected, with one inverter reporting DC overvoltage during grid connection;	
F83	Bus Overvoltage (Secondary CPU1)		Disconnect the AC output side switch and the DC input side switch, wait for 5 minutes, then close the AC output side switch and the DC input side switch. If the fault persists, contact the dealer or after-sales service center.
F84	P-Bus Overvoltage (Secondary CPU1)		

Fault Code	Fault Name	Possible Cause	Recommended Action
F85	N-Bus Overvoltage (Secondary CPU1)	BUS overvoltage, possible causes: 1. PV voltage is too high; 2. Inverter BUS voltage sampling is abnormal; 3. Poor isolation of the dual-split transformer at the inverter's rear end causes mutual interference when two inverters are grid-connected, with one inverter reporting DC overvoltage during grid connection;	
F86	Bus Overvoltage (Secondary CPU2)		Disconnect the AC output side switch and the DC input side switch, wait for 5 minutes, then close the AC output side switch and the DC input side switch. If the fault persists, contact the dealer or after-sales service center.
F87	P-Bus Overvoltage (Secondary CPU2)		

Fault Code	Fault Name	Possible Cause	Recommended Action
F88	N-Bus Overvoltage (Secondary CPU2)	BUS overvoltage, possible causes: 1. PV voltage is too high; 2. Inverter BUS voltage sampling is abnormal; 3. Poor isolation of the dual-split transformer at the inverter's rear end causes mutual interference when two inverters are grid-connected, with one inverter reporting DC overvoltage during grid connection;	
F89	P-Bus Overvoltage (CPLD)		Disconnect the AC output side switch and the DC input side switch, wait for 5 minutes, then close the AC output side switch and the DC input side switch. If the fault persists, contact the dealer or after-sales service center.

Fault Code	Fault Name	Possible Cause	Recommended Action
F90	N-Bus Overvoltage (CPLD)	BUS overvoltage, possible causes: 1. PV voltage is too high; 2. Inverter BUS voltage sampling is abnormal; 3. Poor isolation of the dual-split transformer at the inverter's rear end causes mutual interference when two inverters are grid-connected, with one inverter reporting DC overvoltage during grid connection;	
F91	FlyCap Software Overvoltage	FlyCap overvoltage, possible causes: 1. PV voltage is too high; 2. Inverter FlyCap voltage sampling is abnormal;	Disconnect the AC output side switch and the DC input side switch, wait for 5 minutes, then close the AC output side switch and the DC input side switch. If the fault persists, contact the dealer or after-sales service center.
F92	FlyCap Hardware Overvoltage		

Fault Code	Fault Name	Possible Cause	Recommended Action
F93	FlyCap Undervoltage	FlyCap undervoltage, possible causes: 1. PV energy is insufficient; 2. Inverter FlyCap voltage sampling is abnormal;	Disconnect the AC output side switch and the DC input side switch, wait for 5 minutes, then close the AC output side switch and the DC input side switch. If the fault persists, contact the dealer or after-sales service center
F94	FlyCap Precharge Failure	FlyCap precharge failure, possible causes: 1. PV energy is insufficient; 2. Inverter FlyCap voltage sampling is abnormal;	Disconnect the AC output side switch and the DC input side switch, wait for 5 minutes, then close the AC output side switch and the DC input side switch. If the fault persists, contact the dealer or after-sales service center
F95	FlyCap Precharge Abnormal	1. Control loop parameters are unreasonable 2. Hardware damage	Disconnect the AC output side switch and the DC input side switch, wait for 5 minutes, then close the AC output side switch and the DC input side switch. If the fault persists, contact the dealer or after-sales service center

Fault Code	Fault Name	Possible Cause	Recommended Action
F96, F97	String Overcurrent (String 1-n) n: Determined based on the actual number of inverter strings	Possible causes: 1. String overcurrent; 2. String current sensor is abnormal	Disconnect the AC output side switch and the DC input side switch, wait for 5 minutes, then close the AC output side switch and the DC input side switch. If the fault persists, contact the dealer or after-sales service center
F99, F100	String Missing (String 1-n) n: Determined based on the actual number of inverter strings	String fuse is open (if present)	Check if the fuse is open.
F101	Battery 1 Precharge fault	Battery 1 precharge circuit fault (precharge resistor burned out, etc.)	Check if the precharge circuit is in good condition, and if the battery voltage matches the bus voltage after the battery is powered on. If not, contact the dealer or after-sales service center.
F102	Battery 1 Relay Failure	Battery 1 relay cannot operate normally	After powering on the battery, check if the battery relay is working and if a closing sound is heard. If it does not operate, contact the dealer or after-sales service center.

Fault Code	Fault Name	Possible Cause	Recommended Action
F103	Battery 1 Connection Overvoltage	Battery 1 connection voltage exceeds the machine's rated range	Confirm that the battery voltage is within the machine's rated range.
F104	Battery 2 Precharge fault	Battery 2 precharge circuit fault (precharge resistor burned out, etc.)	Check if the precharge circuit is in good condition, and if the battery voltage matches the bus voltage after the battery is powered on. If not, contact the dealer or after-sales service center.
F105	Battery 2 Relay Failure	Battery 2 relay cannot operate normally	After powering on the battery, check if the battery relay is working and if a closing sound is heard. If it does not operate, contact the dealer or after-sales service center.
F106	Battery 2 Connection Overvoltage	Battery 2 connection voltage exceeds the machine's rated range	Confirm that the battery voltage is within the machine's rated range.
F107	On-grid PWM Sync Failure	Abnormality occurred during carrier synchronization grid connection	<ol style="list-style-type: none"> 1. Check if the sync line connection is normal 2. Check if the master/slave settings are normal; 3. Disconnect the AC output side switch and the DC input side switch, wait for 5 minutes, then close the AC output side switch and the DC input side switch. If the fault persists, contact the dealer or after-sales service center.
F108	DSP Communication fault	-	-

Fault Code	Fault Name	Possible Cause	Recommended Action
F109	External STS fault	Abnormal cable connection between inverter and STS	Check if the wiring sequence of the harness between the inverter and the STS corresponds one-to-one in order.
F110	Export Limit Protection	<ol style="list-style-type: none"> 1. Inverter reports error and disconnects from grid 2. meter communication is unstable 3. Reverse power flow condition occurs 	<ol style="list-style-type: none"> 1. Check if the inverter has other error messages. If yes, handle them accordingly; 2. Check if the meter connection is reliable; 3. If this alarm occurs frequently, affecting normal power generation of the power station, contact the dealer or after-sales service center.
F111	Bypass Overload	-	-
F112	Black Start Failure	-	-
F113	Offgrid AC Ins Volt High	-	-
F114	Relay Failure 2	<p>Relay abnormality, causes:</p> <ol style="list-style-type: none"> 1. Relay abnormality (relay short circuit) 2. Relay sampling circuit is abnormal. 3. Abnormal AC side wiring (possible poor connection or short circuit) 	Disconnect the AC output side switch and the DC input side switch, wait for 5 minutes, then close the AC output side switch and the DC input side switch. If the fault persists, contact the dealer or after-sales service center.
F115	SVG Precharge Disabled	SVG precharge hardware failure	Contact the dealer or after-sales service center.

Fault Code	Fault Name	Possible Cause	Recommended Action
F116	Nighttime SVG PID Prevention fault	PID prevention hardware abnormal	
F117	DSP Version Recognition Error	DSP software version recognition error	Disconnect the AC output side switch and the DC input side switch, wait for 5 minutes, then close the AC output side switch and the DC input side switch. If the fault persists, contact the dealer or after-sales service center.
F118	MOS Continuous Overvoltage	<ol style="list-style-type: none"> 1. Software issue causing inverter drive to turn off earlier than flyback drive; 2. Inverter drive circuit abnormal causing inability to turn on; 3. PV voltage is too high; 4. Mos voltage sampling is abnormal; 	Disconnect the AC output side switch and the DC input side switch, wait for 5 minutes, then close the AC output side switch and the DC input side switch. If the fault persists, contact the dealer or after-sales service center.
F119	Bus Short Circuit fault	Hardware damage	If the inverter remains disconnected from the grid after a BUS short circuit fault occurs, contact the dealer or after-sales service center.

Fault Code	Fault Name	Possible Cause	Recommended Action
F120	Bus Sampling Abnormal	1. BUS voltage sampling hardware fault	Disconnect the AC output side switch and the DC input side switch, wait for 5 minutes, then close the AC output side switch and the DC input side switch. If the fault persists, contact the dealer or after-sales service center.
F121	DC Side Sampling Abnormal	1. BUS voltage sampling hardware fault 2. Battery voltage sampling hardware fault 3. Dcrly relay fault	Disconnect the AC output side switch and the DC input side switch, wait for 5 minutes, then close the AC output side switch and the DC input side switch. If the fault persists, contact the dealer or after-sales service center.

Fault Code	Fault Name	Possible Cause	Recommended Action
F122	PV Access Mode Setting Error	<p>There are three PV access modes, taking four MPPTs as an example:</p> <ol style="list-style-type: none"> 1. Parallel mode: i.e., AAAA mode (same-source mode), PV1-PV4 are from the same source, all 4 PV strings connect to the same solar panels 2. Partial parallel mode: i.e., AACC mode, PV1 and PV2 are from the same source, PV3 and PV4 are from the same source 3. Independent mode: i.e., ABCD mode (different-source), PV1, PV2, PV3, PV4 are independent, each of the 4 PV strings connects to a separate solar panel <p>This fault is reported if the actual PV access mode does not match the PV</p>	<p>Check if the PV access mode is set correctly (ABCD, AACC, AAAA), and reset the PV access mode correctly.</p> <ol style="list-style-type: none"> 1. Confirm that the actual connected PV strings are correctly connected; 2. If the PV strings are correctly connected, check via the APP or screen if the currently set "PV Access Mode" corresponds to the actual access mode; 3. If the currently set "PV Access Mode" does not match the actual access mode, use the APP or screen to set the "PV Access Mode" to the mode consistent with the actual situation. After setting, disconnect the PV and AC power and restart; 4. After setting, if the current "PV Access Mode" matches the actual access mode but the fault still occurs, contact the dealer or after-sales service center.

Fault Code	Fault Name	Possible Cause	Recommended Action
		access mode set on the device	

8.4.4 Troubleshooting (Fault Codes F122-F163)

Error Code	Error Name	Error Cause	Troubleshooting Suggestion
F123	Multi-string PV Phase Error	PV Input Mode Setting Error	<p>Check if the PV Access Mode is set correctly (ABCD, AACC, AAAA), and reset the PV Access Mode correctly.</p> <ol style="list-style-type: none"> 1. Confirm that all connected PV strings are correctly wired. 2. If the PV strings are correctly connected, check via the APP or the screen whether the currently set "PV Access Mode" corresponds to the actual connection mode. 3. If the currently set "PV Access Mode" does not match the actual connection mode, use the APP or the screen to set the "PV Access Mode" to the mode consistent with the actual situation. After setting, disconnect and restart the PV and AC power supply. 4. After setting, if the current "PV Access Mode" matches the actual connection mode but the error persists, please contact the dealer or after-sales service center.

Error Code	Error Name	Error Cause	Troubleshooting Suggestion
F124	Battery 1 Reverse Polarity fault	Battery 1 positive and negative terminals are reversed	Check if the polarities of the battery and the machine terminals are consistent.
F125	Battery 2 Reverse Polarity fault	Battery 2 positive and negative terminals are reversed	Check if the polarities of the battery and the machine terminals are consistent.
F126	Abnormal Battery Connection	Abnormal Battery Connection	Check if the battery is working normally.
F127	BAT Overtemperature	Battery temperature is too high, possible reasons: 1. Poor ventilation at the inverter installation location. 2. Ambient temperature is too high. 3. Internal fan operation is abnormal.	Disconnect the AC output side switch and the DC input side switch, close them after 5 minutes. If the error persists, please contact the dealer or after-sales service center.
F128	Ref Voltage Abnormal	Reference circuit fault	Disconnect the AC output side switch and the DC input side switch, close them after 5 minutes. If the error persists, please contact the dealer or after-sales service center.
F129	Cabinet Under Temperature	Cabinet temperature is too low, possible reason: Ambient temperature is too low.	Disconnect the AC output side switch and the DC input side switch, close them after 5 minutes. If the error persists, please contact the dealer or after-sales service center.

Error Code	Error Name	Error Cause	Troubleshooting Suggestion
F130	AC Side SPD fault	AC side surge protective device failure	Replace the AC side surge protective device.
F131	DC Side SPD fault	DC side surge protective device failure	Replace the DC side surge protective device.
F132	Internal Fan Abnormal	Internal fan abnormal, possible reasons: 1. Fan power supply abnormal. 2. Mechanical fault (blockage). 3. Fan aging or damage.	Disconnect the AC output side switch and the DC input side switch, close them after 5 minutes. If the error persists, please contact the dealer or after-sales service center.
F133	External Fan Abnormal	External fan abnormal, possible reasons: 1. Fan power supply abnormal. 2. Mechanical fault (blockage). 3. Fan aging or damage.	
F134	PID Diagnosis Abnormal	PID hardware fault or PV voltage too high causing PID pause	PID pause warning caused by high PV voltage requires no action. PID hardware fault can be cleared by turning the PID switch off and then on. Replace the PID device.

Error Code	Error Name	Error Cause	Troubleshooting Suggestion
F135	Trip-Switch Trip Warning	Possible reasons: Overcurrent or PV reverse polarity caused the trip switch to open.	Contact the dealer or after-sales service center. The trip reason is PV short circuit or reverse polarity. Check if there are historical PV short circuit warnings or historical PV reverse polarity warnings. If they exist, maintenance personnel need to check the corresponding PV condition. After checking and confirming no fault, you can manually close the trip switch and clear this warning via the APP interface's clear historical fault operation.
F136	Historical PV IGBT Short Circuit Warning	Possible reasons: Overcurrent caused the trip switch to open.	Contact the dealer or after-sales service center. Maintenance personnel need to check the Boost hardware and external string for faults according to the historical PV short circuit warning subcode. After checking and confirming no fault, you can clear this warning via the APP interface's clear historical fault operation.

Error Code	Error Name	Error Cause	Troubleshooting Suggestion
F137 , F138	Historical PV Reverse Polarity Warning (String 1-n) (n: determined by the actual number of inverter strings)	Possible reasons: PV reverse polarity caused the trip switch to open.	Contact the dealer or after-sales service center. Maintenance personnel need to check if the corresponding string has reverse polarity according to the historical PV reverse polarity warning subcode, and check if there is a voltage difference in the PV panel configuration. After checking and confirming no fault, you can clear this warning via the APP interface's clear historical fault operation.
F139	Flash Read/Write Error Warning	Possible reasons: 1. Flash content changed. 2. Flash end of life.	1. Upgrade to the latest firmware. 2. Contact the dealer or after-sales service center.
F140	Meter Comm Loss	This warning may only occur when anti-backflow function is enabled. Possible reasons: 1. Meter not connected. 2. Incorrect wiring of the communication cable between the meter and the inverter.	Check the meter wiring, connect the meter correctly. If the error persists after checking, please contact the dealer or after-sales service center.
F141	PV Panel Type Identification Failure	PV panel identification hardware abnormal	Contact the dealer or after-sales service center.

Error Code	Error Name	Error Cause	Troubleshooting Suggestion
F142	PV String Mismatch	PV string mismatch, two strings under the same MPPT have different open-circuit voltage configurations	Check the open-circuit voltage of the two strings, configure strings with the same open-circuit voltage under the same MPPT path. Long-term string mismatch poses safety risks.
F143	CT Not Connected	CT not connected	Check the CT wiring.
F144	CT Reverse Connection	CT reverse connection	Check the CT wiring.
F145	PE Loss	Ground wire not connected	Check the ground wire.
F146	String Terminal High Temperature (String 1~8)	Register 37176 PV terminal temperature warning subcode 1 is set	-
F147	String Terminal High Temperature (String 9~16)	Register 37177 PV terminal temperature warning subcode 2 is set	-
F148	String Terminal High Temperature (String 17~20)	Register 37178 PV terminal temperature warning subcode 3 is set	-

Error Code	Error Name	Error Cause	Troubleshooting Suggestion
F149	Historical PV Reverse Polarity Warning (String 33~48)	Possible reasons: PV reverse polarity caused the trip switch to open.	Contact the dealer or after-sales service center. Maintenance personnel need to check if the corresponding string has reverse polarity according to the historical PV reverse polarity warning subcode, and check if there is a voltage difference in the PV panel configuration. After checking and confirming no fault, you can clear this warning via the APP interface's clear historical fault operation.
F150	Battery 1 Low Voltage	Battery voltage below set value	-
F151	Battery 2 Low Voltage	Battery voltage below set value	-
F152	Low Voltage of Battery Power	Battery in non-charging mode, voltage below shutdown voltage	-
F153	Battery 1 High Voltage	-	-
F154	Battery 2 High Voltage	-	-

Error Code	Error Name	Error Cause	Troubleshooting Suggestion
F155	Online Low Insulation Resistance	<p>1. PV string short circuit to protective earth.</p> <p>2. PV string installed in a humid environment for a long time with poor line-to-ground insulation.</p>	<p>1. Check the impedance of the PV string to protective earth. If a short circuit is found, rectify the short point.</p> <p>2. Check if the inverter's protective earth wire is correctly connected.</p> <p>3. If it is confirmed that the impedance is indeed below the default value in rainy conditions, please reset the "Insulation Resistance Protection Point".</p>
F156	Micro-grid Overload Warning	backup port input current too high	Occasional occurrence requires no action; if this warning occurs frequently, please contact the dealer or after-sales service center.
F157	Manual Reset	-	-
F158	Generator Phase Sequence Abnormal	-	-
F159	Multiplexed Port Configuration Abnormal	Multiplexed (Generator) port is configured for micro-grid or large load, but a generator is actually connected	Use the APP to change the multiplexed (generator) port configuration.
F160	EMS Forced Off-grid	EMS issued forced off-grid command, but off-grid function is not enabled	Enable the off-grid function.

Error Code	Error Name	Error Cause	Troubleshooting Suggestion
F161	Passive Anti-islanding Protection	-	-
F162	Grid Type Fault	Actual grid type (two-phase or split-phase) does not match the set safety standard	Switch to the corresponding safety standard according to the actual grid type.
F163	Grid Phase Instability	Grid abnormal: Grid voltage phase change rate does not comply with local grid standard.	<p>1. If it occurs occasionally, it may be a temporary grid anomaly. The inverter will resume normal operation after detecting a normal grid, requiring no manual intervention.</p> <p>2. If it occurs frequently, please check if the grid frequency is within the allowable range. If not, please contact the local power operator.</p>

8.4.5 Fault Phenomenon Handling

Fault Name	Fault Cause	Fault Handling Suggestions
Generator Failure	<ol style="list-style-type: none"> 1. This fault will be displayed continuously if no generator is connected. 2. During generator operation, this fault will be triggered if generator safety regulations are not met. 	<ol style="list-style-type: none"> 1. If no generator is connected, ignore this fault. 2. If this fault appears when the generator malfunctions, it is normal. Wait for a period after the generator recovers, and the fault will clear automatically. 3. This fault does not affect the normal operation of off-grid mode. 4. If both the generator and grid are connected and meet safety requirements, the grid has priority for grid-connection, and the system will operate in grid-tied mode.
BMS Status Bit Error	BMS module failure	<p>Disconnect the AC output side switch and the DC input side switch. After 5 minutes, close the AC output side switch and the DC input side switch. If the fault persists, please contact the dealer or after-sales service center.</p>
Ambient Overtemperature	<ol style="list-style-type: none"> 1. Poor machine ventilation 2. Hot air flow back to the ambient temperature sampling point 	<p>Disconnect the AC output side switch and the DC input side switch. After 5 minutes, close the AC output side switch and the DC input side switch. If the fault persists, please contact the dealer or after-sales service center.</p>

Fault Name	Fault Cause	Fault Handling Suggestions
PV Terminal Overtemperature	PV terminal overtemperature, possible causes: 1. Poor ventilation at the inverter installation location. 2. Ambient temperature is too high. 3. Internal fan operation is abnormal.	1. Check if the ventilation at the inverter installation location is adequate and if the ambient temperature exceeds the maximum allowable range. 2. If ventilation is poor or the ambient temperature is too high, please improve the ventilation and heat dissipation conditions. 3. If both ventilation and ambient temperature are normal, please contact the dealer or after-sales service center.
BAT Terminal Overtemperature	BAT terminal overtemperature, possible causes: 1. Poor ventilation at the inverter installation location. 2. Ambient temperature is too high.	1. Check if the ventilation at the inverter installation location is adequate and if the ambient temperature exceeds the maximum allowable range.
AC Terminal Overtemperature Warning	AC terminal overtemperature, possible causes: 1. Poor ventilation at the inverter installation location. 2. Ambient temperature is too high. 3. Internal fan operation is abnormal.	2. If ventilation is poor or the ambient temperature is too high, please improve the ventilation and heat dissipation conditions. 3. If both ventilation and ambient temperature are normal, please contact the dealer or after-sales service center.

Fault Name	Fault Cause	Fault Handling Suggestions
BAT Terminal Overtemperature Warning	BAT terminal overtemperature, possible causes: 1. Poor ventilation at the inverter installation location. 2. Ambient temperature is too high.	1. Check if the ventilation at the inverter installation location is adequate and if the ambient temperature exceeds the maximum allowable range. 2. If ventilation is poor or the ambient temperature is too high, please improve the ventilation and heat dissipation conditions. 3. If both ventilation and ambient temperature are normal, please contact the dealer or after-sales service center.
Three-phase on-grid fault	Three-phase external wiring error	Re-wire the connections.
External STS Failure	Abnormal connection cable between inverter and STS	Check if the wiring sequence of the harness connecting the inverter and the STS corresponds one-to-one in order.

Fault Name	Fault Cause	Troubleshooting Recommendation
Parallel Comm Timeout Shutdown	In parallel operation, if a slave unit fails to communicate with the master unit for more than 400 seconds.	Check if the parallel communication harness is securely connected. Check for duplicate slave addresses.
Three-phase off-grid phase loss fault	Phase loss in a three-phase system group.	1. Check if all inverters are powered on. 2. Check if each phase of the three-phase group is connected to an inverter.

Fault Name	Fault Cause	Troubleshooting Recommendation
EPO	External hardware emergency stop button triggered or remote emergency stop command triggered.	<ol style="list-style-type: none"> 1. If it was actively triggered by a remote shutdown, it can be ignored. 2. If not actively triggered, please contact your dealer or the after-sales service center.
High Combustible Gas Concentration	Automatically triggered when the combustible gas device detects a concentration of 20% LEL or higher.	<ol style="list-style-type: none"> 1. After the fault occurs, the unit will automatically open the air damper to exhaust and reduce the concentration. The fault will clear automatically after the concentration remains below 5% LEL for 15 minutes. 2. If the fault triggers a cluster-level fire protection fault, the air damper will be automatically closed. Confirm the damper status within 30s to ensure the cluster-level fire protection operates in a sealed space. 3. Please contact your dealer or the after-sales service center.
Combustible Gas Device Air Damper Open Signal Mismatch with Feedback	Mismatch between the control signal to open the air damper and the feedback signal.	<ol style="list-style-type: none"> 1. Check the harness signal connections for issues. 2. Please contact your dealer or the after-sales service center.
One-Key Shutdown	Check via the App if the one-key shutdown function is enabled.	Disable the one-key shutdown.

Fault Name	Fault Cause	Troubleshooting Recommendation
Offline Shutdown	-	-
Remote Shutdown	-	-
On-Grid SPD Fault	-	<ol style="list-style-type: none"> 1. Try restarting the unit and observe if the fault clears. 2. If the fault persists after restart, please contact your dealer or the after-sales service center.
Off-Grid SPD Fault	-	<ol style="list-style-type: none"> 1. Try restarting the unit and observe if the fault clears. 2. If the fault persists after restart, please contact your dealer or the after-sales service center.
Child Node Communication Failure	Internal Comm Abnormal	<ol style="list-style-type: none"> 1. Try restarting the unit and observe if the fault clears. 2. If the fault persists after restart, please contact your dealer or the after-sales service center.
Dehumidifier Communication Fault	Abnormal communication link between the dehumidifier and the LC control box.	<ol style="list-style-type: none"> 1. Check the communication harness link and observe if the fault clears. 2. Try restarting the unit and observe if the fault clears. 3. If the fault persists after restart, please contact your dealer or the after-sales service center.

Fault Name	Fault Cause	Troubleshooting Recommendation
Combustible Gas Detection Device Communication Fault	<ol style="list-style-type: none"> 1. The combustible gas device was not properly configured with the 485 address set to 2 during factory setup. 2. Abnormal communication link between the combustible gas device and the LC control box. 	<ol style="list-style-type: none"> 1. Check the communication harness link and observe if the fault clears. 2. Try restarting the unit and observe if the fault clears. 3. Use the method provided by the combustible gas device manufacturer to check if the device address is 2. If not, modify it. 4. If the fault persists after restart, please contact your dealer or the after-sales service center.
DG Communication Failure	Abnormal communication link between the control board and the diesel generator (DG).	<ol style="list-style-type: none"> 1. Check the communication harness link and observe if the fault clears. 2. Try restarting the unit and observe if the fault clears. 3. If the fault persists after restart, please contact your dealer or the after-sales service center.
Battery Over Voltage	<ol style="list-style-type: none"> 1. Individual cell voltage too high. 2. Abnormal voltage sensing wires. 	Record the fault phenomenon, restart the battery, wait a few minutes, and confirm if the fault disappears. If the problem persists after restart, please contact the after-sales service center.
Battery Undervoltage	<ol style="list-style-type: none"> 1. Total battery voltage too high. 2. Abnormal voltage sensing wires. 	
	<ol style="list-style-type: none"> 1. Individual cell voltage too low. 2. Abnormal voltage sensing wires. 	

Fault Name	Fault Cause	Troubleshooting Recommendation
	1. Total battery voltage too low. 2. Abnormal voltage sensing wires.	
Battery Overcurrent	1. Charging current too high, abnormal battery current limiting: sudden change in temperature and voltage values. 2. Inverter response abnormal.	
	Battery discharge current too high.	
Battery Overtemperature	1. Ambient Overtemperature. 2. Abnormal temperature sensor.	
Battery Undertemperature	1. Ambient temperature too low. 2. Abnormal temperature sensor.	
Battery Terminal Overtemperature	Terminal temperature too high.	

Fault Name	Fault Cause	Troubleshooting Recommendation
Battery Imbalance	<ol style="list-style-type: none"> 1. Excessive temperature difference. At different stages, the battery will limit power, i.e., limit charge/discharge current. Therefore, this issue is generally difficult to occur. 2. Cell capacity degradation leads to excessive internal resistance, causing large temperature rise and thus large temperature difference during overcurrent. 3. Poor welding of cell tabs leads to rapid cell temperature rise during overcurrent. 4. Temperature sampling issue. 5. Loose power line connections. 	

Fault Name	Fault Cause	Troubleshooting Recommendation
	<ol style="list-style-type: none"> 1. Inconsistent cell aging levels. 2. Issues with slave board chips can also cause excessive cell voltage difference. 3. Slave board balancing issues can also cause excessive cell voltage difference. 4. Harness issues. 	
Insulation Resistance	Insulation resistance damaged.	Check if the ground wire is properly connected, restart the battery. If the problem persists after restart, please contact the after-sales service center.
Pre-charging Failure	Pre-charging Failure	Indicates that during pre-charging, the voltage across the pre-charge MOS consistently exceeds the specified threshold. After powering off and restarting, observe if the fault persists. Check if wiring is correct and if the pre-charge MOS is damaged.
Harness Fault	Battery sensing harness poor contact or disconnected.	Check the wiring, restart the battery. If the problem persists after restart, please contact the after-sales service center.
	Cell voltage sensing harness poor contact or disconnected.	Check the wiring, restart the battery. If the problem persists after restart, please contact the after-sales service center.

Fault Name	Fault Cause	Troubleshooting Recommendation
	Cell temperature sensing harness poor contact or disconnected.	
	Dual-channel current comparison error too large, or abnormal current sensing harness loop.	
	Dual-channel voltage comparison error too large, or MCU vs AFE voltage comparison error too large, or abnormal voltage sensing harness loop.	
	Temperature sensing harness loop abnormal, poor contact, or disconnected.	
	Overvoltage level 5 or overtemperature level 5, tripping the three-terminal fuse.	
Relay or MOS Overtemperature	Relay or MOS overtemperature.	This fault indicates the MOS temperature has exceeded the specified threshold. Power off and let it sit for 2 hours for temperature recovery.

Fault Name	Fault Cause	Troubleshooting Recommendation
Shunt Overtemperature	Shunt overtemperature.	This fault indicates the shunt temperature has exceeded the specified threshold. Power off and let it sit for 2 hours for temperature recovery.
BMS1 Other Fault 1 (Residential Storage)	Relay or MOS Open Circuit	<ol style="list-style-type: none"> 1. Upgrade software, power off and let it sit for 5 minutes, restart and see if the fault persists. 2. If it persists, replace the battery pack.
	Relay or MOS Short Circuit	<ol style="list-style-type: none"> 1. Upgrade software, power off and let it sit for 5 minutes, restart and see if the fault persists. 2. If it persists, replace the battery pack.
	Communication abnormal between master and slave racks, or cell inconsistency between racks.	<ol style="list-style-type: none"> 1. Check the slave battery information and software version, and whether the communication cable connection to the master is normal. 2. Upgrade software.
	Battery system loop harness abnormal, causing the interlock signal not to form a loop.	Check if the terminal resistor is installed correctly.
	BMS and PCS Communication Abnormal	<ol style="list-style-type: none"> 1. Confirm if the communication cable interface definitions between the inverter and the connected battery are correct. 2. Please contact the after-sales service center to check backend data and observe if the inverter and battery software match correctly.

Fault Name	Fault Cause	Troubleshooting Recommendation
	BMS Master and Slave Controller Communication Harness Abnormal	1. Check wiring and restart the battery. 2. Upgrade the battery software. If the problem persists after restart, please contact the after-sales service center.
	Communication loss between main negative chips.	
	Circuit Breaker, Shunt Trip Abnormal	1. Power off and let it sit for 5 minutes, restart and see if the fault persists. 2. Observe the blind-mate connectors at the bottom of the PACK and PCU, check if communication pins are loose or misaligned.
	MCU Self-test Failure	Upgrade software, restart the battery. If the problem persists after restart, please contact the after-sales service center.
	1. Software version too low or BMS board damaged. 2. Large number of parallel inverters causing excessive inrush current during battery pre-charge.	1. Upgrade software and observe if the fault persists. 2. For parallel systems, black-start the battery first, then start the inverters.
	MCU Internal Fault	Upgrade software, restart the battery. This usually indicates MCU or external component damage. If the problem persists after restart, please contact the after-sales service center.

Fault Name	Fault Cause	Troubleshooting Recommendation
	Total control current exceeds specified threshold.	<ol style="list-style-type: none"> 1. Power off and let it sit for 5 minutes, restart and see if the fault persists. 2. Check if the inverter power setting is too high, exceeding the bus load capacity.
	Inconsistent cells in parallel battery racks.	Confirm if the cells in the parallel battery racks are consistent.
	Reverse polarity connection of parallel battery racks.	Check if the positive and negative terminals of the parallel battery racks are reversed.
	Severe overtemperature, overvoltage, etc., triggering the fire protection system.	Contact the after-sales service center.
Air Conditioner Failure	Air conditioner abnormal failure.	Try restarting the system. If the fault is not resolved, please contact the after-sales service center.
	Cabinet door not closed.	Check if the cabinet door is properly closed.
	Supply voltage too high.	Confirm if the supply voltage meets the air conditioner input voltage requirements. After confirmation, power on again.
	Insufficient supply voltage.	
	No voltage input.	
	Unstable supply voltage.	

Fault Name	Fault Cause	Troubleshooting Recommendation
	Compressor voltage unstable.	Try restarting the system. If the fault is not resolved, please contact the after-sales service center.
	Sensor poor contact or damaged.	
	Air conditioner fan abnormal.	
BMS1 Other Fault 2 (Residential Storage)	Internal voltage or current abnormal in DCDC.	Refer to specific DC fault content.
	DCDC overload or heatsink temperature too high, etc.	
	Cell sensing abnormal or inconsistent aging levels.	Please contact the after-sales service center.
	Fan operation not executed normally.	Please contact the after-sales service center.
	Output terminal screws loose or poor contact.	<ol style="list-style-type: none"> 1. Power off the battery, check wiring and output terminal screw condition. 2. After confirmation, restart the battery and observe if the fault persists. If it persists, please contact the after-sales service center.
Battery used for too long or cells severely damaged.	Please contact the after-sales service center to replace the pack.	

Fault Name	Fault Cause	Troubleshooting Recommendation
	1. Software version too low or BMS board damaged. 2. Large number of parallel inverters causing excessive inrush current during battery pre-charge.	1. Upgrade software and observe if the fault persists. 2. For parallel systems, black-start the battery first, then start the inverters.
	Heating film damaged.	Please contact the after-sales service center.
	Heating film three-terminal fuse blown, heating function unavailable.	Please contact the after-sales service center.
	Software model, Cell Type, hardware model mismatch.	Check if the software model, SN, Cell Type, and hardware model are consistent. If not, please contact the after-sales service center.
	Thermal management board communication cable disconnected. Pack fan fault signal triggered.	1. Power off and let it sit for 5 minutes, restart and see if the fault persists. 2. If the fault does not recover, contact after-sales to replace the pack.
DCDC Fault	Output port voltage too high.	Check the output port voltage. If the output port voltage is normal and the fault does not clear by itself after restarting the battery, please contact the after-sales service center.

Fault Name	Fault Cause	Troubleshooting Recommendation
	DCDC module detects battery voltage exceeding maximum charging voltage.	Stop charging, discharge to SOC below 90% or let it sit for 2 hours. If ineffective and the fault persists after restart, please contact the after-sales service center.
	Heatsink temperature too high.	Let the battery sit for 1 hour for the heatsink temperature to drop. If ineffective and the fault persists after restart, please contact the after-sales service center.
	Battery discharge current too high.	Check if the load exceeds the battery's discharge capability. Turn off the load or stop the PCS for 60 seconds. If ineffective and the fault persists after restart, please contact the after-sales service center.
	Output port power harness positive/negative reversed with parallel racks or PCS.	Turn off the battery manual switch, check if the output port wiring is correct, restart the battery.
	Output power relay cannot close.	Check if the output port wiring is correct and if there is a short circuit. If ineffective and the fault persists after restart, please contact the after-sales service center.
	Power device temperature too high.	Let the battery sit for 1 hour for the internal power device temperature to drop. If ineffective and the fault persists after restart, please contact the after-sales service center.
	Relay welded/stuck.	If the fault persists after restart, please contact the after-sales service center.

Fault Name	Fault Cause	Troubleshooting Recommendation
Battery Rack Circulating Current Failure	<ol style="list-style-type: none"> 1. Cell imbalance. 2. First power-on without full charge calibration. 	Record the fault phenomenon, restart the battery, wait a few minutes, and confirm if the fault disappears. If the problem persists after restart, please contact the after-sales service center.
BMS1 Other Fault 3 (Utility Storage)	Communication abnormal with Linux module.	<ol style="list-style-type: none"> 1. Check if the communication cable connection is normal. 2. Upgrade software, restart the battery and observe if the fault persists. If it persists, please contact the after-sales service center.
	Cell temperature rise too fast.	Cell abnormal, contact after-sales to replace the pack.
	SOC below 10%.	Charge the battery.
	SN writing does not comply with rules.	Check if the SN digit count is normal. If abnormal, please contact the after-sales service center.
	<ol style="list-style-type: none"> 1. Communication abnormal within battery rack daisy chain. 2. Inconsistent cell aging levels between battery racks. 	<ol style="list-style-type: none"> 1. Check the pack contact condition within a single battery rack. 2. Confirm the usage status of each rack, such as cumulative charge/discharge capacity, cycle count, etc. 3. Please contact the after-sales service center.
	High humidity inside pack.	-
	Fuse blown.	Contact after-sales to replace the pack.
	Battery low power.	Charge the battery.
BMS1 Other Fault 4 (Utility Storage)	Circuit breaker abnormal.	Contact after-sales to replace the pack.

Fault Name	Fault Cause	Troubleshooting Recommendation
	External device abnormal.	Contact after-sales to replace the pack.
Contactor Failure 1	-	-
Contactor Failure 2	-	-
Overload Protection (Ksic)	Sustained overload (exceeding 690kVA) for 10s.	Please contact the after-sales service center.
Overload Protection (Smart Port)	Sustained overload (exceeding 690kVA) for 10s.	Please contact the after-sales service center.
Overcurrent Protection (Ksic)	-	-
Overcurrent Protection (Smart Port)	-	-
Master AC On Meter Comm Error	<ol style="list-style-type: none"> 1. Meter may not be connected to the master. 2. Meter communication cable may be loose. 	<ol style="list-style-type: none"> 1. Check if the meter is connected to the master. 2. Check if the meter communication cable is loose.
Parallel Slave Meter Error	Meter connected to a slave unit.	Set the unit with the meter connected as the master.
Slave AC On Timeout with Master	<ol style="list-style-type: none"> 1. Slave address setting error. 2. Slave communication cable loose. 	<ol style="list-style-type: none"> 1. Check if the slave address is duplicated. 2. Check if the parallel communication cable is loose.

8.5 Routine Maintenance



When performing operation and maintenance on the inverter, please power it off. Operating the equipment while energized may cause inverter damage or pose an electric shock hazard.

Maintenance Content	Maintenance Method	Maintenance Cycle
System Cleaning	Check the heat sink and air inlet/outlet for foreign objects or dust.	Once/Six Months - Once/Year
Fan	Check if the fan operates normally, for any abnormal noise, and if its appearance is normal.	Once/Year
DC Switch	Turn the DC switch on and off 10 times consecutively to ensure its proper function.	Once/Year
Electrical Connections	Check electrical connections for looseness, inspect cable appearance for damage or exposed copper.	Once/Six Months - Once/Year
Sealing	Check if the sealing of the equipment's cable entry holes meets requirements. If gaps are too large or unsealed, reseal them.	Once/Year

9 Inverter Parameters

Technical Data	GW7.5K-MS-G40	GW8.5K-MS-G40	GW9.999K-MS-G40
Input			
Max.Input Power (W)* ¹	15000	17000	19998
Max.Input Voltage (V)* ²	600	600	600
MPPT Operating Voltage Range (V)	40~560	40~560	40~560
MPPT Voltage Range at Nominal Power (V)	160-500	185-500	210-500
Start-up Voltage (V)	50	50	50
Nominal Input Voltage (V)	360	360	360
Max. Input Current per MPPT (A)	20	20	20
Max. Short Circuit Current per MPPT (A)	26	26	26
Max.Backfeed Current to The Array (A)	0	0	0
Number of MPPT	3	3	3
Number of Strings per MPPT	1	1	1
Output			
Nominal Output Power (W)	7500	8500	9999
Nominal Output Apparent Power (VA)	7500	8500	9999
Max. AC Active Power (W)	7500	8500	9999

Technical Data	GW7.5K-MS-G40	GW8.5K-MS-G40	GW9.999K-MS-G40
Max. AC Apparent Power (VA)	7500	8500	9999
Nominal Power at 40°C (W) (Only for Brazil)	7500	8500	/
Max Power at 40°C (Including AC Overload) (W) (Only for Brazil)	7500	8500	/
Nominal Output Voltage (V)	220/230/240, L/N /PE	220/230/240, L /N/PE	220/230/240, L/N/P E
Output Voltage Range (V)	160~270 (according to local standard)		
Nominal AC Grid Frequency (Hz)	50/60	50/60	50/60
AC Grid Frequency Range (Hz)	45~55 / 55~65	45~55 / 55~65	45~55 / 55~65
Max. Output Current (A)	34.1	38.7	45.5
Max. Output Fault Current (Peak and Duration) (A/us)	28185	33298	109/3
Inrush Current (Peak and Duration) (A/ms)	23/15	26/15	30/15
Nominal Output Current (A) (at 220V)	34.1@220V 32.6@230V 31.3@240	38.7@220V 37.0@230V 35.5@240V	45.5@220V 43.5@230V 41.7@240V
Power Factor	~1 (Adjustable from 0.8 leading to 0.8 lagging)	~1 (Adjustable from 0.8 leading to 0.8 lagging)	~1 (Adjustable from 0.8 leading to 0.8 lagging)

Technical Data	GW7.5K-MS-G40	GW8.5K-MS-G40	GW9.999K-MS-G40
Max. Total Harmonic Distortion	<3%	<3%	<3%
Efficiency			
Max. Efficiency	97.8%	97.9%	97.9%
European Efficiency	97.2%	97.3%	97.3%
Protection			
PV String Current Monitoring	Integrated	Integrated	Integrated
PV Insulation Resistance Detection	Integrated	Integrated	Integrated
Residual Current Monitoring	Integrated	Integrated	Integrated
DC Reverse Polarity Protection	Integrated	Integrated	Integrated
Anti-islanding Protection	Integrated	Integrated	Integrated
AC Overcurrent Protection	Integrated	Integrated	Integrated
AC Short Circuit Protection	Integrated	Integrated	Integrated
AC Overvoltage Protection	Integrated	Integrated	Integrated
DC Switch	Integrated	Integrated	Integrated
DC Surge Protection	Type II	Type II	Type II
AC Surge Protection	Type II	Type II	Type II
AFCI	Optional	Optional	Optional
Emergency Power Off	Optional	Optional	Optional

Technical Data	GW7.5K-MS-G40	GW8.5K-MS-G40	GW9.999K-MS-G40
Rapid Shutdown	Optional	Optional	Optional
Remote Shutdown	Optional	Optional	Optional
Power Supply at Night	Optional	Optional	Optional
General Data			
Operating Temperature Range (°C)	-25~+60	-25~+60	-25~+60
Relative Humidity	0~100%	0~100%	0~100%
Max. Operating Altitude (m)	4000	4000	4000
Cooling Method	Natural Convection	Natural Convection	Natural Convection
Display	LCD, WLAN + APP	LCD, WLAN + APP	LCD, WLAN + APP
Communication	RS485, WIFI, LAN, Bluetooth, 4G	RS485, WIFI, LAN, Bluetooth, 4G	RS485, WIFI, LAN, Bluetooth, 4G
Communication Protocols	Modbus-RTU (SunSpec Compliant)		
Weight (kg)	16	16	16
Dimension W×H×D (mm)	493*365*187	493*365*187	493*365*187
Noise Emission (dB)	< 30	< 30	< 30
Topology	Non-isolated	Non-isolated	Non-isolated
Self-consumption at Night (W)	<1	<1	<1

Technical Data	GW7.5K-MS-G40	GW8.5K-MS-G40	GW9.999K-MS-G40
Ingress Protection Rating	IP66	IP66	IP66
Anti-corrosion Class	C4	C4	C4
DC Connector	MC4(4-6mm ²)	MC4(4-6mm ²)	MC4(4-6mm ²)
AC Connector	Plug and play connector (Max.16mm ²)		
Environmental Category	4K4H	4K4H	4K4H
Pollution Degree	III	III	III
Overvoltage Category	DC II / AC III	DC II / AC III	DC II / AC III
Protective Class	I	I	I
Active Anti-islanding Method	SMS(Slip-mode frequency) +AFD* ³		
The Decisive Voltage Class (DVC)	PV: C AC: C Com: A		
Country of Manufacture	China	China	China

Technical Data	GW10K-MS-G40	GW7.5K-MS-G41	GW8K-MS-G40
Input			
Max.Input Power (W)* ¹	20000	13500	14400
Max.Input Voltage (V)* ²	600	600	600
MPPT Operating Voltage Range (V)	40~560	40~560	40~560
MPPT Voltage Range at Nominal Power (V)	210-500	220-500	240-500

Technical Data	GW10K-MS-G40	GW7.5K-MS-G41	GW8K-MS-G40
Start-up Voltage (V)	50	50	50
Nominal Input Voltage (V)	360	360	360
Max. Input Current per MPPT (A)	20	20	20
Max. Short Circuit Current per MPPT (A)	26	26	26
Max.Backfeed Current to The Array (A)	0	0	0
Number of MPPT	3	2	2
Number of Strings per MPPT	1	1	1
Output			
Nominal Output Power (W)	10000	7500	8000
Nominal Output Apparent Power (VA)	10000	7500	8000
Max. AC Active Power (W)	10000	7500	8000
Max. AC Apparent Power (VA)	10000	7500	8000
Nominal Power at 40°C (W) (Only for Brazil)	10000	7500	8000
Max Power at 40°C (Including AC Overload) (W) (Only for Brazil)	10000	7500	8000
Nominal Output Voltage (V)	220/230/240, L/N /PE	220/230, L/N/PE	220/230, L/N/PE

Technical Data	GW10K-MS-G40	GW7.5K-MS-G41	GW8K-MS-G40
Output Voltage Range (V)	160~270(according to local standard)		
Nominal AC Grid Frequency (Hz)	50/60	50/60	50/60
AC Grid Frequency Range (Hz)	45~55 / 55~65	45~55 / 55~65	45~55 / 55~65
Max. Output Current (A)	45.5	34.1	36.4
Max. Output Fault Current (Peak and Duration) (A/us)	109/3	28185	28185
Inrush Current (Peak and Duration) (A/ms)	30/15	23/15	23/15
Nominal Output Current (A) (at 220V)	45.5@220V 43.5@230V 41.7@240V	34.1@220 32.6@230	36.4@220V 34.8@230V
Power Factor	~1 (Adjustable from 0.8 leading to 0.8 lagging)		
Max. Total Harmonic Distortion	<3%	<3%	<3%
Efficiency			
Max. Efficiency	97.9%	97.8%	97.8%
European Efficiency	97.3%	97%	97%
Protection			
PV String Current Monitoring	Integrated	Integrated	Integrated
PV Insulation Resistance Detection	Integrated	Integrated	Integrated

Technical Data	GW10K-MS-G40	GW7.5K-MS-G41	GW8K-MS-G40
Residual Current Monitoring	Integrated	Integrated	Integrated
DC Reverse Polarity Protection	Integrated	Integrated	Integrated
Anti-islanding Protection	Integrated	Integrated	Integrated
AC Overcurrent Protection	Integrated	Integrated	Integrated
AC Short Circuit Protection	Integrated	Integrated	Integrated
AC Overvoltage Protection	Integrated	Integrated	Integrated
DC Switch	Integrated	Integrated	Integrated
DC Surge Protection	Type II	Type II	Type II
AC Surge Protection	Type II	Type II	Type II
AFCI	Optional	Optional	Optional
Emergency Power Off	Optional	Optional	Optional
Rapid Shutdown	Optional	Optional	Optional
Remote Shutdown	Optional	Optional	Optional
Power Supply at Night	Optional	Optional	Optional
General Data			
Operating Temperature Range (°C)	-25~+60	-25~+60	-25~+60
Relative Humidity	0~100%	0~100%	0~100%
Max. Operating Altitude (m)	4000	4000	4000

Technical Data	GW10K-MS-G40	GW7.5K-MS-G41	GW8K-MS-G40
Cooling Method	Natural Convection	Natural Convection	Natural Convection
Display	LCD, WLAN + APP	LCD, WLAN + APP	LCD, WLAN + APP
Communication	RS485, WIFI, LAN, Bluetooth, 4G	RS485, WIFI, LAN, Bluetooth, 4G	RS485, WIFI, LAN, Bluetooth, 4G
Communication Protocols	Modbus-RTU (SunSpec Compliant)		
Weight (kg)	16	16	16
Dimension W×H×D (mm)	493*365*187	493*365*187	493*365*187
Noise Emission (dB)	< 30	< 30	< 30
Topology	Non-isolated	Non-isolated	Non-isolated
Self-consumption at Night (W)	<1	<1	<1
Ingress Protection Rating	IP66	IP66	IP66
Anti-corrosion Class	C4	C4	C4
DC Connector	MC4(4-6mm ²)	MC4(4-6mm ²)	MC4(4-6mm ²)
AC Connector	Plug and play connector (Max.16mm ²)		
Environmental Category	4K4H	4K4H	4K4H
Pollution Degree	III	III	III
Overvoltage Category	DC II / AC III	DC II / AC III	DC II / AC III

Technical Data	GW10K-MS-G40	GW7.5K-MS-G41	GW8K-MS-G40
Protective Class	I	I	I
Active Anti-islanding Method	SMS(Slip-mode frequency) +AFD*3		
The Decisive Voltage Class (DVC)	PV: C AC: C Com: A		
Country of Manufacture	China	China	China

*1: The actual value depends on the specific input power of the PV panel.

*2: When the input voltage ranges from 560 V to 600 V, the inverter will enter standby state. When the input voltage returns to the MPPT operating voltage range of 40 V to 560 V, the inverter will resume normal operation.

*3: AFD: Active Frequency Drift with Positive Feedback

10 Explanation of Terms

Explanation of Overvoltage Categories

- **Overvoltage Category I:** Equipment connected to circuits with measures to limit transient overvoltages to a fairly low level.
- **Overvoltage Category II:** Energy-consuming equipment supplied by fixed distribution installations. This category includes appliances, portable tools, and other household and similar loads. If special requirements for reliability and suitability are imposed on such equipment, then Overvoltage Category III is used.
- **Overvoltage Category III:** Equipment in fixed distribution installations, where the reliability and suitability of the equipment must meet special requirements. This includes switching devices in fixed distribution installations and industrial equipment permanently connected to fixed distribution installations.
- **Overvoltage Category IV:** Equipment used in the power supply of distribution installations, including measuring instruments and overcurrent protection devices, etc.
- **Explanation of Damp Location Categories**

Environmental Parameters	Level		
	3K3	4K2	4K4H
Temperature Range	0~+40°C	-33~+40°C	-33~+40°C
Humidity Range	5% to 85%	15% to 100%	4% to 100%

- **Explanation of Environmental Categories:**
 - **Outdoor Inverter:** Ambient air temperature range from -25°C to +60°C, suitable for Pollution Degree 3 environment;
 - **Indoor Type II Inverter:** Ambient air temperature range from -25°C to +40°C, suitable for Pollution Degree 3 environment;
 - **Indoor Type I Inverter:** Ambient air temperature range from 0°C to +40°C, suitable for Pollution Degree 2 environment;
- **Explanation of Pollution Degree Categories**
 - **Pollution Degree 1:** No pollution or only dry non-conductive pollution;
 - **Pollution Degree 2:** Generally, only non-conductive pollution, but occasional temporary conductive pollution due to condensation must be considered;

- **Pollution Degree 3:** There is conductive pollution, or non-conductive pollution becomes conductive due to condensation;
- **Pollution Degree 4:** Persistent conductive pollution, for example, pollution caused by conductive dust or rain/snow.

11 Related Product Manuals Acquisition

Document Name	Official Website Link
EzLink3000 Quick Installation Guide	https://en.goodwe.com/Ftp/EN/Downloads/User%20Manual/GW_EzLink_Quick%20Installation%20Guide-EN.pdf
4G Kit-CN-G20 & 4G Kit-CN-G21 Quick Installation Guide	https://en.goodwe.com/Ftp/Installation-instructions/4G-KIT.pdf
WiFi/LAN Kit-20 & WiFi Kit-20 Quick Installation Guide	https://en.goodwe.com/Ftp/Installation-instructions/WiFi-LAN-Kit-20.pdf
GMK110 & GMK110D Quick Installation Guide	https://en.goodwe.com/Ftp/Installation-instructions/GMK110-110D.pdf
GM1000 & GM3000 & GM1000 Quick Installation Guide	https://en.goodwe.com/Ftp/Installation-instructions/Smart-Meter.pdf
GMK330 & GMK360 & GM330 Quick Installation Guide	https://en.goodwe.com/Ftp/Installation-instructions/GMK330-360.pdf